

mistral[®]

INSTALLATION & OPERATION INSTRUCTIONS

A5尺寸
70克双胶纸
黑白印刷
此红色文字不印刷



7kg Front Load Washing Machine

**Model No. MBLD348W-F
MBLD348W**

GSM Retail Australia Pty Ltd ABN: 53 007 682 475
For Warranty and technical queries: Australia 1300 373 199
For Warranty and technical queries: New Zealand 0800 764 912
www.mistral.com.au

V3 April 2024

Thank you

This Mistral Washing Machine carries a 2 year replacement warranty, be sure to retain your installation and user manual and receipt.

For Technical queries please contact
Aust: **1300 373 199**
NZ: **0800 764 912**

Contents

Safety notices	1
Parts and features	3
Installation	4
The functions of the control panel	7
How to use washer	10
Cleanness and maintenance	13
Troubleshooting guide	14
Parameters	15
Electric Diagram	16

PREFACE

This washing machine conforms to current safety requirements. Inappropriate use can, however, lead to personal injury and damage to property. To avoid the risk of accidents and damage to the washing machine, please read this manual carefully before using it for the first time. They contain important information on its installation, safety, use and maintenance.
Keep this manual in a safe place for future reference.

Safety Notices

Before Use



WARNING

Read and understand thoroughly these safety instructions before use. The items indicated here are very important safety precautions, which must be followed. We cannot be held liable for damage caused by non-compliance with the warning and safety instructions or resulting from incorrect use or operation.

Cleaning and user maintenance shall not be made by children without supervision. Children of less than 3 years should be kept away unless continuously supervised. The new hose-sets supplied with the appliance are to be used and the old hose-sets should not be reused.

This appliance is not intended for use by persons (including children) with reduced physical, sensory or mental capabilities, or lack of experience and knowledge, unless they have been given supervision or instruction concerning use of the appliance by a person responsible for their safety. Children should be supervised to ensure that they do not play with the appliance.

This appliance can be used by children aged from 8 years and above and persons with reduced physical, sensory or mental capabilities or lack of knowledge if they have been given supervision or instruction concerning use of the appliance in a safe way and understand the hazards involved. Children shall not play with the appliance. Cleaning and user maintenance shall not be made by children without supervision.

This appliance is intended to be used in household and similar applications such as:

- staff kitchen areas in shops, offices and other working environments;**
- farm houses;**
- by clients in hotels, motels and other residential type environments;**
- bed and breakfasts type environments;**
- areas for communal use in blocks of flats or in launderettes.**

For washing machines having ventilation openings on the base, the washing machines cannot be washing on the carpet.

- Before setting the washing machine, check it for any externally visible damage. Do not install or use a damaged washing machine.
- Before connecting the washing machine, ensure that the connection data on the plate (voltage and current) match the electricity supply. If in any doubt, consult a qualified electrician.
- The electrical safety of this washing machine can only be guaranteed when continuity is complete between it and an effective earthing system which complies with current local and national safety regulations. It is most important that this basic safety requirement is present and regularly tested, and where there is any doubt the household wiring system should be inspected by a qualified electrician. The manufacturer cannot be held liable for the consequences of an inadequate earthing system.
- Do not connect the washing machine to the mains electricity supply by an extension lead. Extension leads do not guarantee the required safety of the appliance.
- Unauthorized repairs could result in unforeseen dangers for the user, for which manufacturer can not accept liability. Repairs should only be undertaken by an approved service technician. Ensure current is not supplied to the machine until after maintenance of repair work has been carried out.

Safety Notices

Before Use

If the connection cable is damaged or broken, it must only be replaced by an approved service technician to protect the user from danger.

Faulty components must only be replaced by genuine manufacturer original spare parts. Only when these parts are fitted the safety standards of the machine can be guaranteed.



Note

THIS WASHING MACHINE MUST BE EARTHED.



Correct use

- To avoid the risk of personal injury or damage to the washing machine, do not install it in place where it is damp and where it suffers from rainfall.
- Do not install the washing machine in place where it suffers from the sun directly, in which plastic or components will be damaged. It will be shortened the life of your washing machine.
- Do not install the washing machine in place where temperatures below freezing may occur. Frozen hoses may burst or split. The reliability of the electronic control unit may be impaired at temperatures below freezing point.
- Do not shoot the washing machine with water when you clean it.
- Keep the washing machine away from fire or heat sources.
- Before using the washing machine for the first time, make sure that the transit bolts at the rear of the machine have been removed. During spinning, transit bolts which is still in place may result in damage to both the machine and adjacent furniture or appliances.
- Turn off the tap if the machine is to be left for any length of time (e.g. holiday), especially if there is no floor drain (gully) in the immediate vicinity.
- Take care to ensure that foreign objects (e.g. nails, pins, coins, paper clips) do not find their way into the machine with the laundry. These may damage components of the machine (e.g. drum), which in turn can result in damage to the laundry.
- Do not wash water-repellent things (e.g. raincoats) with washing machine.
- Only remove laundry from the washing machine once the drum has stopped turning. Reaching into a moving drum is extremely dangerous and could result in injury.



Safety with children

- Keep children away from the washing machine at all times. To avoid the risk of injury do not allow children to play on or near it or to play with its controls. Supervise children whilst you are using it.
- Older children may only use the washing machine if its operation has been clearly explained to them and they are able to use it safely, recognizing the dangers of misuse.
- For machines with a 'porthole' door, remember that the porthole glass will be hot when washing at very high temperatures. Do not let children touch it.

Parts and Features

Before Use

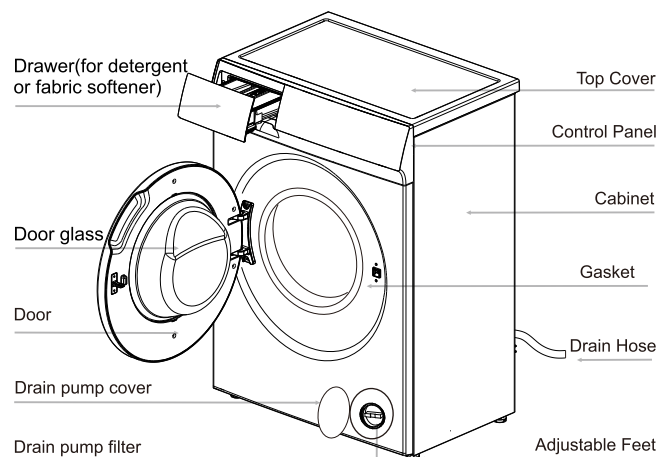

Note Unscrew the drain pump filter to let water run out when the machine is not used for a long time.

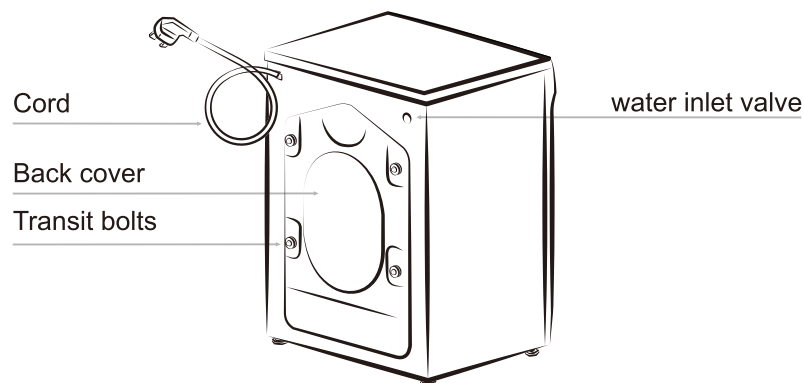

Note The drawing of machine in the manual is only used for instruction. It may be vary from the model you buy.

Installation

Before Use

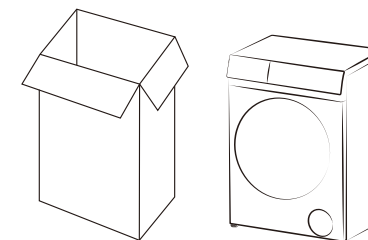

Backout packing

- Remove all the packing (including the foam base) or the vibration and noise may occur.
- Dispose all the wrappage safety and keep them out of the reach of children. Danger of suffocation!
- It is normal that water drops appear on the packing plastic bag and the door glass. This is due to the testing with water of the machine in factory.

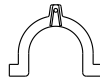

Accessories

Make sure that you have received all of the items shown below.

Accessories	Name	Qty.	Accessories	Name	Qty.
	Inlet hose	1		"U" piece	1
	transit bolts caps	4		Manual	1

Removing transit bolts

- Remove all the transit bolts at the back of the machine with tools.
- Plug the holes with the transit bolts caps supplied.

Note Strong vibration, noise or failures may occur if the transit bolts are not removed.

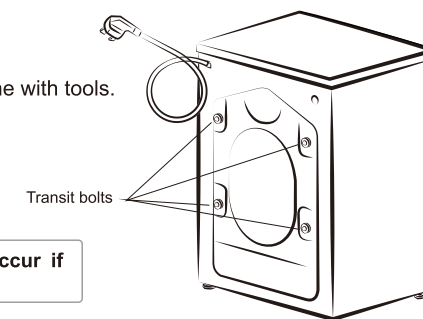

- Keep the transit bolts for future transportation. Whenever the machine is transported, the transit bolts must be refitted.

Installation

Use process

Installation place requirement

- A concrete floor is the most suitable installation surface for a washing machine, being far less prone to vibration during the spin cycle than wooden floorboards or carpeted surface.
- The machine must be level and securely positioned. The distance between the machine and wall must be more than 10 cm.
- To avoid vibrations during spinning, the machine should not be installed on soft floor coverings.

Level adjustment

The machine must stand perfectly level on all four feet to ensure safe and proper operation. Incorrect installation may increase electricity and water consumption and may cause the machine to move about. To do these when the machine is not level:

- Using the spanner turn locknut in a anticlockwise direction. Then turn locknuts together with adjust feet to unscrew.
- Hold adjust feet securely with a pipe wrench. Turn locknut again using the spanner until it sits firmly up against the housing.

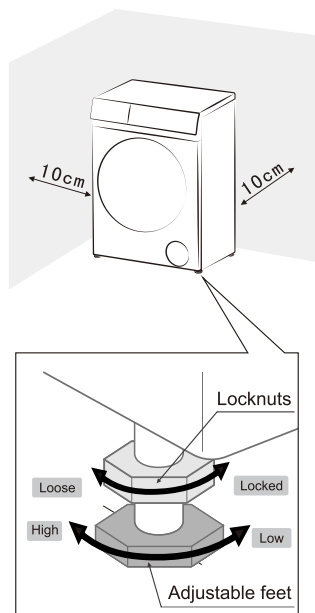

Note Vibration and noise may occur if the locknuts do not sit firmly up against the houses.

Drain hose connection

1. Direct into a sink

If the outlet spigot has not been used before, remove any blanking plug that may be in place. Push the drain hose onto the spigot and secure with a clip if required, ensure a loop is formed in the drain hose to prevent waste from the sink entering the washing machine. If required, the drain hose can be extended to a length of 4 m.

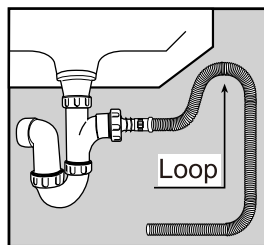
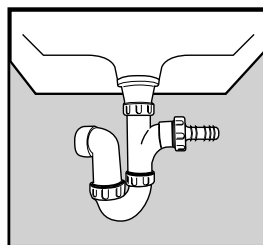

Installation

Use process

2. Connected securely to a standpipe

Firstly form a hook in the end of the drain hose using the "U" piece supplied. Place the drain hose into your standpipe, which should have an internal diameter of approximately 30mm thus ensuring there is an air break between the drain hose and standpipe. When discharging into a standpipe ensure that the top of the standpipe is no more than 90cm and no less than 60cm above floor level.

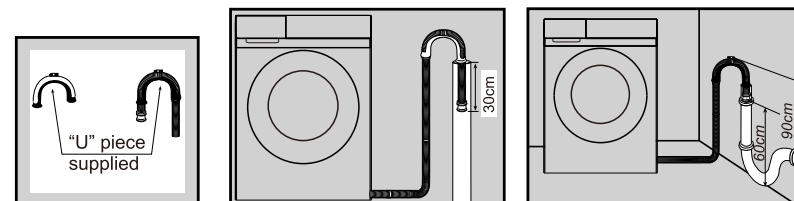

Water inlet connection

Do not use previously employed hoses. Installation should comply with local water authority and building regulations' requirements.

1. Connect the inlet hose to the machine.

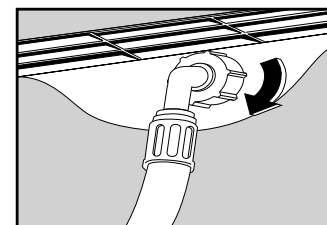

2. Connect the inlet hose to a tap with 3/4" thread.

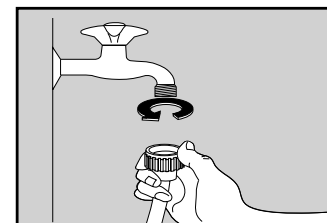

The functions of the control panel

Use process

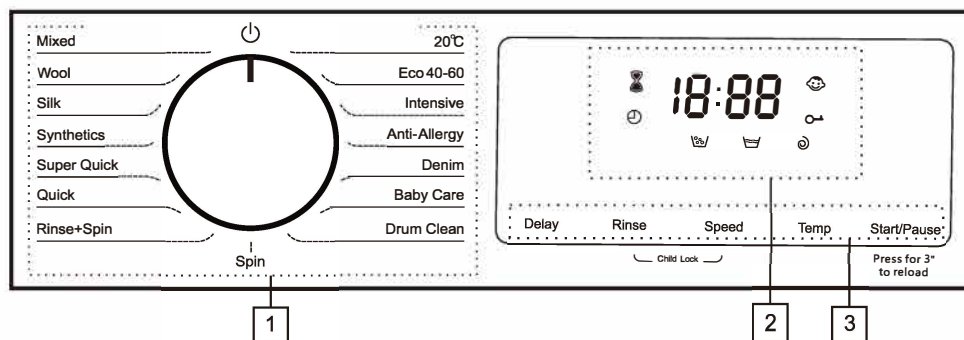

- 1 Programmes: Page 9
- 2 Display: Page 7
- 3 Buttons: Page 8

Digital display: This icon shows the time, speed, rinse times, Error codes.

Display

The display shows the current settings, options or relevant information.

	<p>The digital display can show:</p> <ul style="list-style-type: none"> • Programme duration (e.g. 1:20) • Speed (e.g. 1200, on behalf of 1200 rpm) • Temp (e.g. 20, on behalf of 20°C) • Rinse times (e.g. 2) • Delay time (e.g. 1:2h) • Error codes (e.g. E01)
	Delay time: the light under this icon will be lighting once the display shows the delay time.
	Door lock: the light under this icon will be lighting when door lock is working.
	Child lock: the light under this icon will be lighting once child lock function is selected.
	Washing phase: the light above this icon will flicker during the washing phase.
	Rinse phase: the light above this icon will flicker during the rinse phase.
	Spin and drain phase: the light above this icon will flicker during the spin and drain phase.

The functions of the control panel

Use process

Buttons

The following is the instruction of the buttons and their setting options.

1.Start/pause

Press this button to start or pause a wash cycle. To reload the laundry during a wash cycle, press this button for 3 seconds, and the machine will drain if the water level is too high. The reload function is unavailable if the temperature of the water is too high.

2.Temp

Press this button repeatedly to change the wash temperature.

3.Speed

Press this button repeatedly to change the spin speed.

4.Rinse

Press this button repeatedly to change the rinse times.

5.Delay

Press this button repeatedly to change the delay time.

6.Child lock ("Rinse"+"Speed")

When the machine starts, press the "Rinse" and "Speed" buttons at the same time for a few seconds and the light under the icon "☺" is lighting, then the function works.

Press the same buttons a few seconds to cancel this function.

When the function works, all buttons are not available.



Note For your safety, Do not press the "Start/Pause" button and get out clothes while the machine is running. Because the temperature of water may be high and it may scald you. The door lock will open automatically at the end of a wash cycle while the temperature of the drum is cool down.

The selectable options and functions of different programs

Program	Weight(kg)	Time(min)	Temp (°C)	Rinse times	Spin speed (rpm)
20°C	7	57	20	2/3/4	0/600/800/1000/1200
Eco 40-60	7	200	--	3	1200
Intensive	7	75	--/20/40/60	2/3/4/5	0/600/800/1000/1200
Anti-Allergy	4	131	90	2/3/4/5	0/600/800/1000
Denim	4	102	--/20/40	4/5	0/600/800/1000
Baby Care	4	143	--/20/40/60/80	2/3/4/5	0/600/800/1000/1200
Drum Clean	0	72	60/90	2	600
Spin	7	11	--	--	0/600/800/1000/1200
Rinse+Spin	7	16	--	1/2/3/4	0/600/800/1000/1200
Quick	2	30	--	2/3	0/600/800/1000/1200
Super Quick	1.5	15	--	1/2	0/600/800/1000/1200
Synthetics	3.5	72	--/20/30/40/60	2/3/4	0/600/800/1000/1200
Silk	2	42	--/20/30/40	2/3/4	0/600
wool	2	50	--/20	2/3/4	0/600
Mixed	4	78	--/20/30/40/60	2/3/4/5	0/600/800/1000/1200

The functions of the control panel

Use process

Washing programme chart

Programme	Washing symbol	Fabric
20°C		Cottons, linens or cotton mix fabrics, e.g. table linen, towelling, underwear, T-shirts etc.
Eco 40-60		Normally soiled cotton laundry. Most favorable program in terms of com-bined water and energy consumption. Basis for the values indicated on the Energy Label.
Intensive		Cottons, linens or cotton mix fabrics, e.g. table linen, towelling, underwear, T-shirts etc.
Anti-Allergy		Washing clothes at 90°C , which would help for sterilization and disinfection.
Denim		Jeans, denim or denim mix fabrics.
Drum Clean		This program is used to clean the drum. Do not put any clothes into the drum while running this program.
Baby Care		Normally soiled baby clothes made of cotton and/or linen. The suds are rinsed out even more thoroughly, which helps to protect sensitive baby skin.
Spin		Separate spin for cotton and linen items
Rinse+Spin		This programme can be used for rinsing items which can be washed in a Cotton programme. Do not add any detergent.
Quick		Small loads of items which require freshening up and which can be washed in a Cotton programme.
Super Quick		Small loads of items which require freshening up and which can be washed in a Cotton program.
Synthetics		Synthetic or mixed fabrics, underwear, coloured garments, non-shrink shirts
Silk		Fine laundry made of delicate fabrics or silk, which needs gentle treatment
wool		Machine-washable or hand-washable wool or wool blend fabrics. If the care label does not specify a temperature, wash using the cold setting. Also suitable for hand-washable silks. Reduce the spin speed.
Mixed		Lightly to normally soiled robust laundry made of cotton, linen, artificial fibers andv their blends. Only wash similar colors together in one wash load.

How to use washer

Use process

Before washing clothes for the first time, you must run a complete cycle without clothes.

To do these:

- 1.Connect the power and turn on the tap.
- 2.Turn the knob to position “ 20°C ” .
- 3.Press the button “Start/Pause” .

There is some residual water in the machine because of the testing in factory. It can remove the residual water and other possible dirt in the tub.

Washing preparation

- 1.Connect the inlet hose well and turn on the tap.
- 2.After making sure the power socket is grounded reliably, insert the power plug into the power socket.
- 3.Place the drain hose well.

Preparation of clothes

1. Sort the laundry by color and by care label. Most garments have a textile care label in the collar or side seam.
2. Make sure all the pockets are empty, Foreign objects (e.g. nails, coins, paper clips, etc.) can cause damage to garments and components in the machine.
3. Close any zips, fasten hooks and eyes etc before washing.
4. Dark textiles often contain excess dye and should be washed separately several times before being included in a mixed load. Always wash whites and coloureds separately.
5. Badly soiled areas, stains etc. should be pre-treated with liquid detergent, stain removers etc.
6. Turn over the clothes which pill easily and is with woolen surface before putting them into the machine.

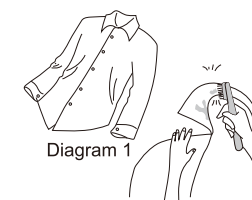

Diagram 1



Diagram 2



Diagram 3

Put clothes into the washer

Unfold the laundry and load loosely in the drum. Mixing both large and small items gives better wash results and also helps distribute the load evenly during spinning. The most efficient use of energy and water is achieved when a full load is washed. However, do not overload as this causes creases and reduces cleaning efficiency.



Note

Make sure that no garments are nipped between the door and the seal.

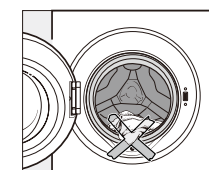

How to use washer

Use process

Using the detergent drawer

1. Open the drawer and add adequate detergent into main wash compartment marked "III" or "II".
2. Add the fabric softener into compartment marked "☼" or "☼".
Do not exceed the maximum level mark.
3. Close the drawer.

The right amount to dispenser will depend on the following:

- The quantity of laundry
- The soiling level of the laundry
 - Lightly soiled
No visible dirt or stains. Possibly slight body odour.
 - Normally soiled
Visibly dirty and/or just a few slight stains.
 - Heavily soiled
Visible dirt and stains and/or dried on soiling.
- The water hardness level.

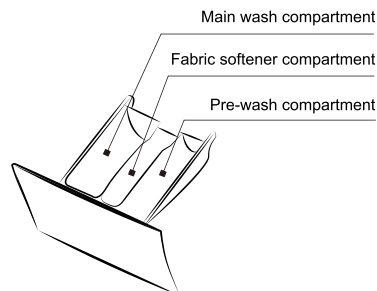

It is recommended to use low foaming powder for all washing temperature programs.

Washing steps

1. Turn on the water tap, and connect the power.
2. Open the door, and put the cloth into the drum one by one.
3. Close the door, and put suitable amount of detergent and fabric softener into the dispenser, then close the drawer.
4. Choose a program you need.
5. Press "Start/Pause" button to start the washing machine.
6. When the cycle is finished, there is a warning tone sound.



The machine is fitted with a balance control device, which ensures the machine is stable during the spin. To protect the machine, it will cut in if the laundry is not evenly distributed in the drum. The laundry is redistributed by reverse rotation of the drum. This may happen several times before the unbalance disappears and normal spinning can resume. If, after about 20 minutes, the laundry is still not evenly distributed in the drum, the machine will not spin. In this case, redistribute the load manually and reselect the spin programme.



When washing cycle is finished, the machine will change into standby mode. And the machine will be sleeping after 10 minutes without any control on the control panel.



Turn the knob to wake up the washing machine, when it goes into the sleeping mode.

How to use washer

Use process

Door lock

- When the machine is started, the door lock is locked.
- When the temperature inside the drum is above 60°C, the door lock is locked.
- When the water is above a certain level, the door lock is locked.
- When the washing cycle is finished, the door lock is unlocked.

Important:

Do not try to open the door when the washing cycle is not finished or power supply is cut off during the washing cycle, because the temperature may be high and you may be scalded.

Cleanness and Maintenance

Use process



Disconnect the machine from the mains electricity supply and withdraw the plug from the socket before cleaning the machine.



The washing machine must not be hosed down.

Cleaning the exterior

Clean the exterior with a mild non-abrasive cleaning agent or soap and water using a well wrung-out cloth. Wipe dry with a soft cloth.



Do not use solvents, abrasive cleaners, glass cleaners or all-purpose cleaning agents. These might damage plastic surfaces and other components because of the chemicals they contain.

The washing drum

Clean the drum every 3 months by using the "Drum Clean" programme.

Cleaning the drawer

Remove detergent residues regularly. Clear the drawer following these:

- Pull out the drawer until a resistance is felt. Press down the release catch and at the same time pull the drawer right out of the machine.
- Remove the siphon from compartment and clean it.
- Clean the dispenser using a brush and warm water.

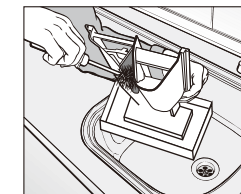
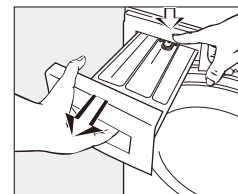

Cleanness and Maintenance

After use

Cleaning the drawer housing

Use a bottle brush to remove detergent residues inside the drawer housing.

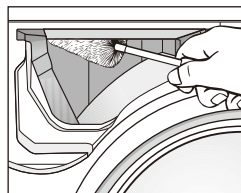

Cleaning the water inlet filter

Use pointed nose pliers to withdraw the plastic filter. Clean, put back and secure. These filter should be checked every 6 months or so, or more often if there are frequent interruptions to the water supply.

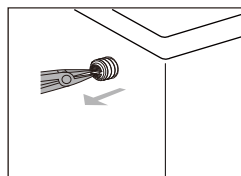

Note

The filter must be put back in place after cleaning.

Cleaning the drain pump filter

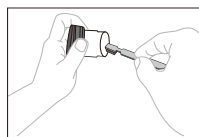
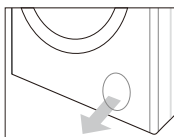

1. Disconnect the machine from the mains electricity supply and open the lower cover with a screwdriver.

2. Place a container under the pump. Unscrew and remove the filter.

3. Clean the filter carefully.

Important:

If the machine is exposed to temperatures below 0°C, certain precautions should be taken.



Note

The filter should be cleaned every 2 months or when there is fault that the "E03" is on the screen.

Troubleshooting guide

Difficult explanation

Problem	Error Code	Possible Cause	Solutions
The water of machine fills overtime.	E01	<ol style="list-style-type: none"> 1. Water tap is not open. 2. Drain hose is put down. 3. Water inlet valve is damaged. 	<ol style="list-style-type: none"> 1. Open the water tap. 2. Hook up the hose. 3. Change the water inlet valve.
There is a Door lock alarm.	E02	<ol style="list-style-type: none"> 1. The door is not locked well. 2. Garments is caught between the door and seal. 3. Door lock is damaged. 	<ol style="list-style-type: none"> 1. Lock the door well. 2. Put the garment into the drum. 3. Change the door lock.
The machine drains overtime.	E03	<ol style="list-style-type: none"> 1. The drain hose is squashed or kinked. 2. The drain pump filter is block. 3. The drainage system pipes are blocked. 	<ol style="list-style-type: none"> 1. Check the drain hose. 2. Clean the filter. 3. Check the drainage system and clean it.
Water overflows the machine. / Water sensor works abnormal.	E04	<ol style="list-style-type: none"> 1. The water inlet valve is damaged. 2. The connection between the water sensor and wire is not secure. 3. The water sensor is damaged. 	<ol style="list-style-type: none"> 1. Change the water inlet. 2. Check the connection and ensure it is secure. 3. Change the water sensor.
The motor does not work.	E05	<ol style="list-style-type: none"> 1. The connection between the motor and wire is not secure. 2. The motor is protected because of over-heat. 3. The motor is damaged. 	<ol style="list-style-type: none"> 1. Check the connection and ensure it is secure. 2. Check if the machine is overloaded. Switch off the machine, and retry when the motor becomes cool. 3. Change the motor.
There is a heater fault.	E06	<ol style="list-style-type: none"> 1. The connection between the heater and wire is not secure. 2. The heater is damaged. 	<ol style="list-style-type: none"> 1. Check the connection and ensure it is secure. 2. Change the heater.
There is a temperature sensor fault.	E07	<ol style="list-style-type: none"> 1. The connection between the temperature sensor and wire is not secure. 2. The temperature sensor is damaged. 	<ol style="list-style-type: none"> 1. Check the connection and ensure it is secure. 2. Change the temperature sensor.

Parameters

Appendix

Power	Model	MBLD348W-F / MBLD348W
Power		220-240V~;50Hz
Rated Power		2100W
Water Pressure		0.02-0.8Mpa
Net Weight /Gross Weight		52kg/56kg
Outer dimension(WxDxH)mm		595x450x845

Energy-efficient test program entrance guide:

Choose the program “ Eco 40-60 ”.

Data can vary from the nominal values given depending on water pressure, water hardness, water inlet temperature, room temperature, type and volume of load, fluctuations in the electricity supply and any extra options selected.

Important:

If the machine is exposed to temperatures below 0°C, certain precautions should be taken.

1. Turn off the water tap.
2. Unscrew the inlet hose.
3. Unhook the drain hose from the rear support and position the end of this hose and that of the inlet hose in a bowl. Run the spin programme.
4. Disconnect the appliance.
5. Screw the inlet hose and reposition the drain hose.
6. When you intend to start the machine up again, make sure that the room temperature is above 0°C.

Electric Diagram

Appendix

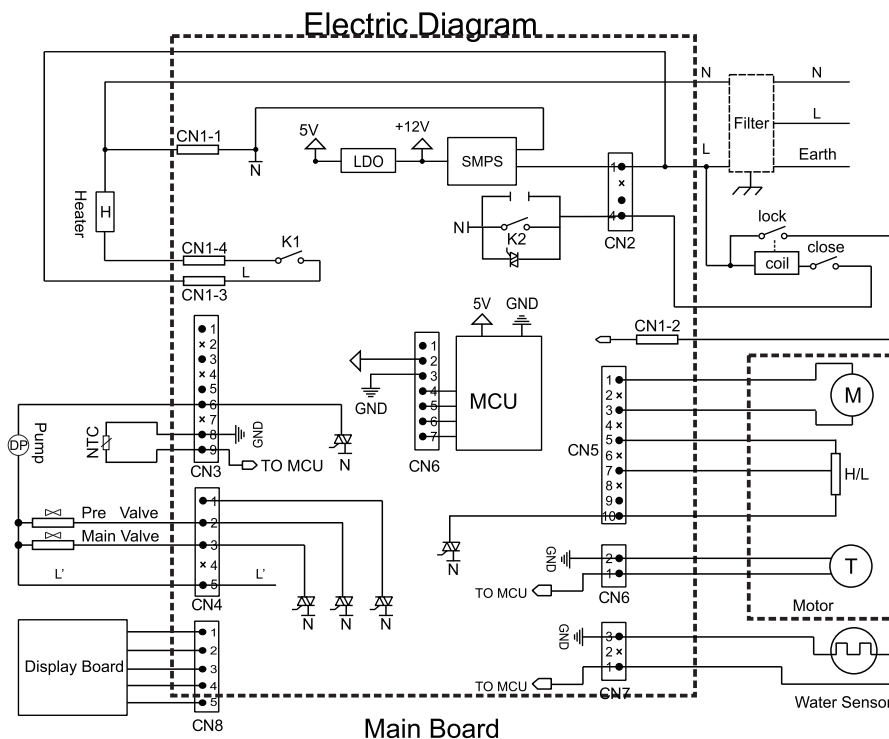

Correct Disposal of this product



This symbol on the product, or in its packaging, indicates that this product may not be treated as household waste. Instead, it should be taken to the appropriate waste collection point for the recycling of electrical and electronic equipment. By ensuring this product is disposed of correctly, you will help prevent potential negative consequences for the environment and human health, which could otherwise be caused by the inappropriate waste handling of this product. For more detailed information about the recycling of this product, please contact your local council, your household waste disposal service, or the shop where you purchased the product.

WARRANTY

1.1 In this warranty:

1.1.1 Australian Consumer Law means the law as set out in Schedule 2 of the Competition and Consumer Act 2010;

1.1.2 **Company** means GSM Retail Australia Pty Ltd ABN 53 007 682 475 of 142-144 Fullarton Road, Rose Park SA 5067. Telephone 1300 373 199. Email admin@gsmretailgroup.com

1.1.3 **Consumer** means a "consumer" as that term is defined in Section 3 of the Australian Consumer Law as the original purchaser of a Mistral product;

1.1.4 **Consumer Guarantees** means the guarantees under the Australian Consumer Law;

1.1.5 **You** means the Consumer.

1.2 Nothing in this warranty affects any person's rights under the Australian Consumer Law. The benefits to any Consumer under this warranty are in addition to the rights and remedies available under any Consumer Guarantees.

1.3 Subject to the other clauses of this warranty, the Company warrants to the Consumer that the Mistral product will be free of manufacturing defects and will perform to the Company's specifications.

1.4 The benefit of this warranty extends only to the Consumer as original purchaser of a Mistral product which is installed in a domestic household area.

*The in Home warranty does not apply to Commercial and or industrial usage. *Please See 1.7.7 for additional information

1.5 This warranty commences on the date of purchase of the Mistral product by the Consumer and continues for the benefit only of the Consumer until the expiry of two (2) year (**Warranty Period**).

1.6 If within the Warranty Period a manufacturing defect is discovered in the Mistral product or it fails to perform to the Company's specifications as a result of some defect in materials, components or workmanship (Defect) then the Company will, at its option, repair the Mistral product or supply a replacement Mistral product free of charge. A replacement Mistral product may differ from the original product purchased by the Consumer.

1.7 This warranty will not apply to any Mistral product:

1.7.1 Installed by any person other than a qualified tradesperson; or

1.7.2 Subjected to misuse, neglect, negligence or accidental damage; or

1.7.3 Operated in any way contrary to any operating or maintenance instructions; or

1.7.4 Improperly handled, installed or maintained; or

1.7.5 Altered or modified prior to or after installation; or

1.7.6 Damaged directly or indirectly by power surges, electrical storm damage or connection to incorrect power supply

1.7.7 Industrial and or Commercial usage is inclusive of staff areas in office/ shop environments, hotel/ motel or other similar accommodation or rental type properties including Bed and Breakfast establishments.

The Australian Consumer Law requires the inclusion of the following statement with this warranty:

Our goods come with guaranteed that cannot be excluded under the Australian Consumer Law. You are entitled to a replacement or refund for a major failure and for compensation for any other reasonably foreseeable loss or damage. You are also entitled to have the goods repaired or replaced if the goods fail to be of acceptable quality and the failure

FOR TECHNICAL ENQUIRIES CALL 1300 373 199 (AUSTRALIA) OR 0800 764 912 (NEW ZEALAND)

1.8 You must provide proof of your purchase of the Mistral product and the date of purchase in order to obtain the benefit of this warranty.

1.9 If you live outside the service area of the Company or one of its service agents, this warranty does not cover the cost of transport of the Mistral product for service nor the service agent's traveling costs to and from your home.

1.10 If you are required to transport the Mistral product to the Company or its service agent, you must ensure it is safely disconnected by a qualified tradesman and securely packed and insured. The Company does not accept any responsibility for loss or damage of the Mistral product prior to it being received by the Company or its service agent.

1.11 You will be responsible for all costs of returning a Mistral product to the Company and for redelivery of the Mistral product by the Company (whether it is the original or a repaired and/or a replacement Mistral product) and for any other expenses you incur in claiming under this warranty.

1.12 The Company or its service agent will examine any Mistral product and if the Company determines that it is defective through no fault of the Owner and is otherwise undamaged, the Company will repair or replace the Mistral product in accordance with this warranty.

DO NOT SEND IN THIS WARRANTY

Fill out the following details and file with your purchase invoice.

RETAIN & FILE WITH YOUR RECEIPT

Your Purchase Receipt/Invoice is proof of date of purchase. If you are unable to establish the date of purchase, or if the fault is not covered by this warranty, or if the product is found to be in working order, you will be required to bear all service call charges.

GSM Retail Australia Pty Ltd reserves the right to discontinue items, modify designs and change specifications without incurring obligation.

Whilst every effort is made to ensure that descriptions, specifications and other information in this publication is correct, no warranty is given in respect thereof and the company shall not be liable for any errors therein. Purchased from:

Co. Name:

Address:

Date of Purchase:

Serial number:

NOTE: Consistent with our continuing product development policy, improvements may have been made which render the contents of this packaging slightly different to that shown.

**FOR TECHNICAL ENQUIRIES CALL
1300 373 199 (AUSTRALIA)
0800 764 912 (NEW ZEALAND)**

TO CONNECT YOU TO THE NEAREST AUTHORISED SERVICE CENTRE

G | S | M

Gerard Sourcing & Manufacturing

GSM RETAIL AUSTRALIA PTY LTD

The GSM Retail Australia Pty Ltd Group Companies has a policy of continual improvement throughout the product range. As such the unit contained within may differ slightly from the unit illustrated on the pack.

MADE IN CHINA for the GSM Retail Australia Pty Ltd. Group Companies

