



Espresso Coffee Machine



Instruction Manual

Model: MEM815/MEM815W

Important Safeguards

When using electrical appliances, in order to reduce the risk of fire, electric shock, and/or injury to persons, basic safety precautions should always be followed, including:

For Your Safety

Read all instructions carefully, even if you are quite familiar with the appliance.

- Read Instruction manual carefully.
- This appliance shall not be used by children. Children less than 3 years should be kept away unless continuously supervised.
- Make sure that your outlet voltage corresponds to the voltage stated on the rating label of the coffee machine.
- To protect against fire, electric shock and injury to persons do not immerse cord, plug or unit in water or other liquid.
- Close supervision is necessary when any appliance is used by or near children.
- Unplug from outlet when not in use and before cleaning. Allow to cool before inserting or removing parts and or before cleaning the appliance.
- Do not operate any appliance with a damaged cord or plug or after the appliance malfunctions, or has been damaged in any manner. Return appliance to an authorized service facility for examination, repair or adjustment.
- The use of accessories not recommended by the appliance manufacturer may result in fire, electric shock or injury to persons.
- Do not use outdoors.
- Do not let cord hang over edge of table or counter, or touch hot surface.
- Do not place on or near a hot gas or electric burner, or in a heated oven.
- Do not use appliance for other than intended use.
- Only fill the tank with clean and cold water. Never fill the tank with mineral water, milk or other liquids.
- To disconnect, remove plug from wall outlet. Always hold the plug. Avoid pulling the cord.
- Some parts of appliance are hot when operated, so do not touch with hand.
- Do not leave the appliance on unattended.
- The environment temperature of operating or storing shall be more than 0 degrees Celsius.
- Do not leave the appliance exposed to atmospheric agents (sun, rain and so on).
- This appliance is not intended for use by persons (including children) with reduced physical, sensory or mental capabilities, or lack of experience and knowledge, unless supervised or instruction concerning use of the appliances by a person responsible for their safety.
- Children should be supervised to ensure that they do not play with the appliance.
- This appliance has been incorporated with a grounded plug. Please ensure the wall outlet in your house is well earthed.
- Do not let the coffee machine operate without water.
- Do not use outdoors or for commercial purpose.
- Your appliance must never be switched on through an external timer or any kind of separate remote control system.
- This appliance is intended to be used in household kitchens and similar applications.
- DO NOT PUT FINGERS IN coffee flow outlet and steam release nozzle.
- To prevent damage to the appliance do not use alkaline cleaning agents when cleaning, use a soft cloth and a mild detergent.
- DO NOT overfill the water tank past the max level, doing so poses a scalding, electric shock or fire risk.
- Always operate the appliance on a smooth, even, stable surface. Do not place the unit on or near a hot surface.
- Ensure that the unit is switched off after use.
- Do not move while the appliance in operation.

Warning

If the supply power cord is damaged, the power cord must be replaced by the manufacturer, its service agent or similarly qualified persons in order to avoid a hazard.

This product has not been designed for any uses other than those specified in this booklet.

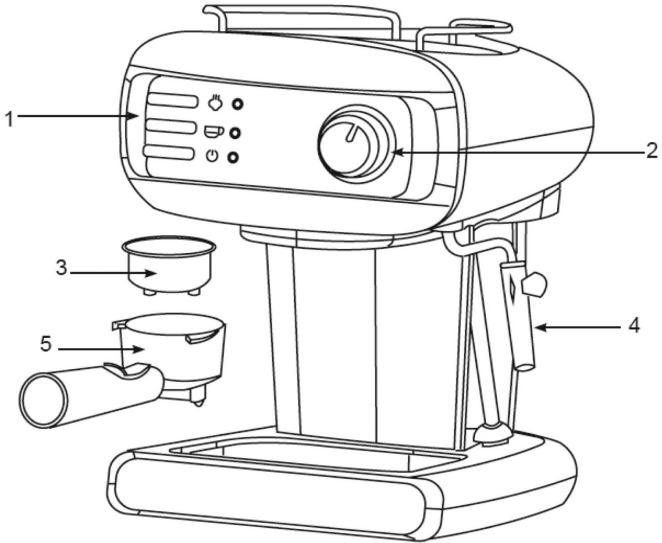

Save These Instructions

Features of Your Espresso Coffee Machine

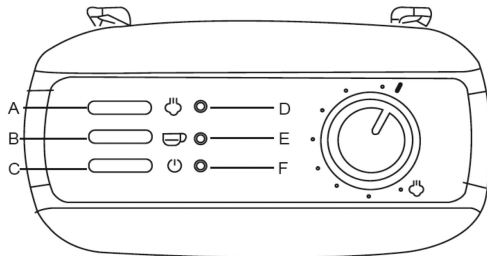
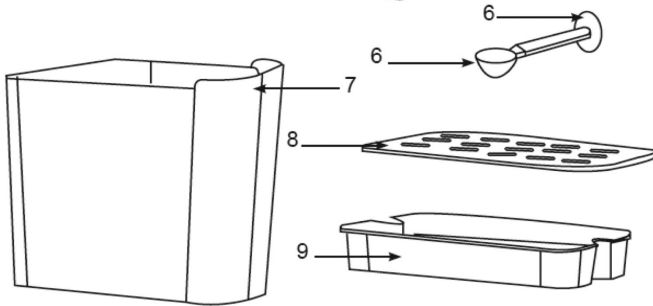

- 1. Control Panel
- 2. Steam Control Knob
- 3. Filter
- 4. Steam Wand
- 5. Coffee Filter Holder
- 6. Measuring Spoon/Tamper
- 7. Water Tank
- 8. Drip Tray Plate
- 9. Drip Tray



- A. Steam Button 
- B. Coffee Button 
- C. On/Off Button 
- D. Steam indicator - Lights up green when the steam temperature is reached.
- E. Coffee indicator - Lights up green when the coffee temperature is reached.
- F. Power indicator - Lights up red when the power button is pressed.

Getting to Know Your Espresso Coffee Machine

Congratulations on the purchase of your new Coffee Machine. Before first using your new Coffee Machine, it is most important that you read and follow the instructions in this use and care booklet, even if you feel you are familiar with this type of appliance.

Your attention is drawn particularly to the section dealing with IMPORTANT SAFEGUARDS. Find a safe and convenient place to keep this booklet handy for future reference.

This appliance has been designed to operate from a standard domestic power outlet. It is not intended for industrial or commercial use.

Before First Use

Before first use, carefully unpack the unit and remove all packaging materials. Wash the Water Tank, Coffee Filter Holder, Filter, Measuring Spoon / Tamper in warm soapy water, then rinse and dry well.

Note: Do not immerse the main body in water or any other liquid.

Set the Coffee Filter Holder

Insert the Coffee Filter(3) into the Coffee Filter Holder(5), make sure you align the notch on the Coffee Filter(3) with the groove on the Coffee Filter Holder(5).

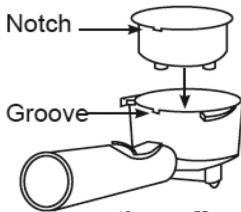

- Rotate the Coffee Filter Holder(5) to the left or right to lock it in place.

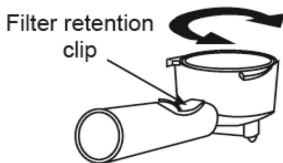

Before You Use The Espresso Coffee Machine

The coffee machine needs to be cleaned with hot water to make sure your first cup of coffee is perfect:

- Remove all the package.
- Make sure that the steam Control Knob (2) is set to '0', Make sure the steam button (☺), and the Coffee Button (☹) are in the Off position (Not pressed in).
- Remove the Water Tank (7) at the rear of the unit.
- Fill the Water Tank (7) with fresh water, making sure do not exceed the 'max' or lower than the 'min' level and insert it back into the rear of the unit.
- Without adding coffee powder, place the Coffee Filter Holder (5) including the empty Coffee Filter (3) into the dock (Fig.1), turn anti-clockwise until it is fixed tight (Fig.2 and 3).

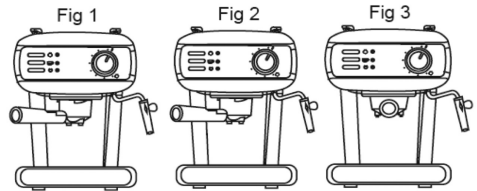

Check the Steam Control Knob (2) is set to '0'. Place an espresso coffee cup onto the Drip Tray Plate(8).

- Connect the mains plug to the mains supply.
- Press the On/Off (☺) button, the Power Indicator light (F) will illuminate red.
- Press the Coffee Button(☹), water will now pump through. While water is flowing out, press the Coffee Button(☹) again. This allows the coffee machine to pre-heat. When the coffee machine has heated, the Coffee Indicator Light (E) will illuminate green, press the Coffee Button(☹) and hot water will flow out.
- After water has been allowed to flow for 1 minute, press the Coffee Button(☹) to stop. Discard the water and clean the cup thoroughly, you can now start making coffee.

Note: There maybe a noise when using the appliance for the first time, this is normal as the appliance pump is exclude air inside, this should disappear after approximately 20 seconds.

How To Use Your Espresso Coffee Machine

Pre-heating The machine

To make a good espresso coffee it is recommended to preheat the coffee machine before making the coffee. Pre-heating includes the Coffee Filter Holder(5) and the cup(s) so that the flavor and temperature of the coffee is not influenced by the cold parts.

- Remove the Water Tank (7) at the rear of the unit.
- Fill the Water Tank (7) with water making sure you do not exceed the 'max' or not lower than 'min' level and insert it back into the rear of the unit.

Note: Insert the water pump suction hose into the water tank prior to positioning water tank into place.

- Insert the Coffee Filter (3) into the Coffee Filter Holder (5), make sure you align the notch on the filter with the groove on the Coffee Filter Holder(5). Rotate the Coffee Filter (3) to the left or right to lock it in Coffee Filter Holder(5).
- Without adding coffee place the Coffee Filter Holder (5) (including the empty coffee filter) into the dock (Fig 1), turn anti-clockwise until it is fixed tight (Fig 2 and 3).
- Check again to ensure the Steam Control Knob (2) is set to '0'. Make sure the Steam Button (☺), and the Coffee Button(☹) are in the "Off" position (Not pressed in). Place an espresso coffee cup(s) onto the Drip Tray Plate (8).

If you need making two small cups of coffee, place one cup under each nozzle of the Coffee Filter Holder (5).

Connect the mains plug to the mains supply. Press the On/Off Button(☺), the red Power Indicator Light (F) will illuminate.

- Press the Coffee Button(☹), water will now pump through. While water is flowing out, press the Coffee Button(☹) again. This allows the coffee machine to preheat. When the coffee machine has heated, the Coffee Indicator Light (E) will illuminate turn green, press the Coffee Button(☹) and hot water will flow out. After about 20 seconds, press the Coffee Button(☹), to stop the water flowing.
- Your coffee machine and cup are now preheated.

Making an Espresso Coffee

- Remove the Coffee Filter Holder (5).
- Using the Measuring spoon (6), add ground coffee powder to the Coffee Filter (3) Only fill half way for one small cup of coffee, fill it full for two cups.
- Press the ground coffee powder tightly using the Tamper (6) at the end of the Measuring Spoon (6).
- Set the Coffee Filter (3) and Coffee Filter Holder (5) under the dock (see Fig.1), and turn it anti-clockwise until it is fixed tight and securely (see Fig.2 and Fig.3).
- Pour out the hot water in the cup(s) from pre-heating, then place your hot cups on to the Drip Tray Plate (8). Make sure the Steam Control Knob (2) is at the '0' position and the Steam Button(☺) is not pressed in.
- Once the Coffee Indicator Light(E) illuminates green, press the Coffee Button(☹), after a brief moment coffee will flow out.
- Press the Coffee Button(☹) to stop when the desired coffee is obtained, or the color of coffee changes to a lighter color - indicating it is weak.
- After your coffee is made, press the On/Off Button(☺). The Power Indicator Light (F) and Coffee Indicator (E) will go out. Your coffee is ready now.

WARNING: Do not leave the coffee machine unattended during coffee making process, as you need operate it manually.

Note: During coffee brewing or steam making process, it is normal for the Coffee Indicator Light (E) to go on and off. This indicates that the thermostat is controlling the heating element to maintain correct temperature.

- On completion of coffee pouring process, you can remove the Coffee Filter Holder (5) by turning it clockwise and dispose of the used coffee granules in the Coffee filter(3, press the filter retention clip on the handle to release the filter from the filter holder.
- Let them cool down completely, then rinse under running water.

Making a Cappuccino Coffee

- Prepare your espresso coffee as detailed above in 'Making Espresso Coffee'. Make sure the cup is big enough to accommodate both the coffee and the frothed milk.
- Make sure that the Steam Control Knob (2) is at the '0' position.
- Press the Steam Button(☞), until the Steam Indicator light (D) illuminates green.
- Fill a jug with about 100 ml of milk for each prepared cappuccino, recommend to use full cream milk at refrigerator temperature (not hot).
- In order to get better milk foam performance, open Steam Control Knob(2) for approximately 15 seconds without putting it in the milk yet. This will clear out any cold water in the system. Then put the Steam Control Knob(2) back to '0' position and conduct the next step.
- Insert the Steam Wand (4) into the milk about 2 cm depth, then turn the Steam Control Knob(2) slowly anti-clockwise. Steam will come out from the Steam Wand (4).
- Frothed milk is produced by moving jug in circular motion while the Steam wand(4) is submerged in the milk.

Warning: Never touch the steam outlet during steam venting and be careful not to get burnt.

Note: Always turn the Steam Control Knob (2) slowly to release the steam in a controlled manner.

- When frothing the milk is complete, you can turn the Steam Control Knob (2) back to the '0' position. The best temperature for frothed milk is 70°C, so take care as there will be plenty of steam coming from it.
- After frothing the milk, put an empty jug under the Steam Wand (4), then turn on the Steam Control Knob (2) and press down the Coffee Button(☞) to the lower position, this will allow hot water to flow from the steam nozzle, operate for approximately 30 seconds, then turn it off again. This will clean out the steam tube.
- Press and release the On/Off Button(☞) to switch the machine off.

- Pour the frothed milk into the espresso coffee you prepared, now the cappuccino is ready.
- Sweeten if desired and sprinkle the froth with a little cocoa powder.

Note: If the steam outlet becomes blocked: Turn the steam knob to '0' position and allow the coffee machine to cool down for about half an hour, then poke the steam outlet several times with a needle about 1mm in diameter until it clears. Finally, press down the Steam Button(☞) and turn on the Steam Control Knob (2) to check if the appliance can produce steam normally when the Steam Indicator (D) green illuminates. Finally, when cool clean the steam outlet with damp cloth.

Note: After steaming, we recommend you allow the machine to cool down for at least for 5 mins before making coffee again. Otherwise a burnt odor may manifest itself in your espresso coffee.

If you want to make more coffee immediately:

- Press and release the Steam Button(☞) to the 'Off' position; dip the Steam Wand(4) into a cup, Press the Coffee Button(☞) the 'On' position and turn on the Steam Control Knob(2) and there will be water flowing from Steam Wand(4); after the Coffee Indicator(E) goes out, press and release the Coffee Button(☞) to the 'Off' position, then turn the Steam Control Knob (2) to '0' position. When the Coffee Indicator(E) illuminates, you can start to make coffee again.

Automatic power 'Off' function

- The coffee machine will turn itself off automatically 25 minutes after pressing the On/Off(☞) button.

Keep Warm Function

The coffee machine can keep your coffee warm momentarily by placing the coffee cup on the Top warm plate.

Empty Drip Tray

Has fixed a red indicator floater in the drip tray, you should empty the drip tray once the indicator was floated up.

Take out drip tray plate and then lift up drip tray from the unit, empty water with coffee residual.

Re-fix the drip tray with it's plate.

De-scaling your Espresso Coffee Machine

When tap water is heated, calcium and other mineral deposits attach themselves to the inside of your coffee machine. Excessive limescale build up will damage the coffee machine, the steam tube is particularly vulnerable to blockage and should be cleaned regularly. We recommend using bottled water or filtered water. If you cannot do this and use water straight from the tap, then it is necessary to de-scale the coffee machine regularly. Do not use vinegar but a commercially available decalcification agent, carefully follow the quantities recommended in the instructions of the agent.

How to de-scale:

To make sure your coffee machine can operate efficiently the internal piping must be cleaned. You should clean away the mineral deposits left every 4 weeks - if you live in a hard water area every 2 weeks. Better still, just use bottled water and none of this will be necessary.

- Fill the Water Tank (7) with water and de-scaler to the 'MAX' level.
- Follow the steps as detailed in 'Pre-heating' above.
- Press the On/Off Button (⏻) to turn on the unit, the Power Indicator (F) (red) will be illuminated, press the Coffee Button (B) , make sure the Steam Button (⌂) is in the off position, when there is water flowing out, shut off the water pump by pressing the Coffee Button (B) again, and wait for a moment. The coffee machine will begin to heat.
- The green Coffee Indicator light (E) will illuminate to show when heating has finished.
- Press down the Coffee Button (⌂) and allow water to flow through, then shut off the water pump and wait for 5 seconds.
- Press the Steam Button (⌂) , and wait until the green Steam Indicator light (D) illuminates. Make steam for 2 minutes, then turn the Steam Control Knob (2) to the '0' position to stop making steam.
- Press the On/Off Button (⏻) to turn off the unit immediately, leave the de-scaler in the unit for at least 15 minutes.
- Empty the tank and refill with clean water. Restart the unit and repeat the above steps at least 3 times with clean water.

Care and Cleaning

Always Switch off and unplug the appliance before cleaning.

- Empty any water that may be inside the coffee machine by turning on the steam function for approximately 2-3 minutes, or until steam no longer comes from the Steam Nozzle.
- Unplug from the mains and allow coffee machine cool down completely before cleaning.
- Clean housing of coffee machine with damp cloth and clean water tank.
- Wash the drip tray and removable drip tray plate regularly, then dry thoroughly.
- Never immerse the housing in water for cleaning.
- Immediately remove the plastic funnel over the steam nozzle by turning it gently after use, wash in warm soapy water and dry thoroughly.
- Clean the metal tube with a damp cloth, dry and replace the plastic funnel.
- Wash the measuring spoon with tamper in warm soapy water and dry thoroughly.

Note: Clean the appliance after every use in order to keep it in good working order.

Note: Do not allow water to sit in the tank, empty the tank after every use.

Trouble shooting

Problem	Possible cause	Solution
Water is leaking from the bottom of the machine	Too much water in the drip tray	Clean out the drip tray
Water is leaking from the outer side of the filter	There is some ground coffee on edge of filter	Clean it off
Tainted taste to the coffee	Allowing water to sit too long, improper cleaning	Clean and de-scale
Low or no steam from the steam wand	Steam wand is clogged up	Clean and de-scale
Poor milk frothing	Using skimmed milk	Full cream milk is best

Specification:

Supply voltage:.....220-240v- 50Hz
 Power consumption:.....850W
 Protection Class:I
 Water Tank Capacity:.....1.2L

Note: As a result of continual improvements, the design and specifications of the product within may differ slightly to the unit illustrated from the packaging.

Notes

Warranty Conditions For Purchase In Australia

Any claim under this warranty must be made within 12 months of the date of purchase of the product. To make a claim under the warranty in Australia, take the product (with proof of purchase) to any Australia Post outlet.

GSM Retail Group bears reasonable, direct, expenses of claiming under the warranty in Australia. You may submit details and proof to Australia Post outlet for consideration or contact our Consumer Service phone number below.

This warranty is provided in addition to other rights and remedies you may have under law: our goods come with guarantees which cannot be excluded under the Australian Consumer Law (if purchased in Australia). You are entitled to replacement or refund for a major failure and to compensation for other reasonably foreseeable loss or damage. You are also entitled to have the goods repaired or replaced if the goods fail to be of acceptable quality and the failure does not amount to a major failure. The warranty excludes damage resulting from product misuse or product neglect. The warranty covers domestic use only and does not apply to commercial applications.

This warranty is given by GSM Retail Group

ABN: 53007682475

For Warranty and technical queries 1300 941 901

Warranty Exclusions

Damage to the appliance or any part through accident, misuse or negligence.

G | S | M

Gerard Sourcing & Manufacturing

GSM Retail Group

Consumer Service Centre : 1300 941 901

GSM Retail Group has a policy of continual improvement throughout the product range.
As such the unit contained within may differ slightly from the unit illustrated on the pack.

MADE IN CHINA for GSM Retail Group
Mistral is a registered trademark of GSM Retail Group

Cat. No.
MEM815/MEM815W
April 2021