

mistral[®]

OPERATION INSTRUCTIONS



60cm White Slide Out Rangehood

Model No. MR60WSOUT

Thank you

Thank you for choosing Mistral Appliances.

All Mistral appliances carry a 2 year In Home warranty be sure to retain your Installation and user manual and receipt.

For all warranty and technical queries please contact

Australia 1300 373 199

New Zealand 0800 764 912

Contents

Safety instructions	2
Product description	3-4
Start using your appliance	5-6
Maintenance	7-8
Warranty	9-10

Safety Instruction

This manual explains the proper installation and use of your range hood, please read it carefully before using even if you are familiar with the product. The manual should be kept in a safe place for future reference. In case of failure, only the Authorised Technical Service may repair this range hood. Otherwise the guarantee will be null and void. All Appliances are for domestic use only.

Never to do:

- This appliance is not intended for use by persons (including children) with reduced physical, sensory and mental capabilities, or lack of experience and knowledge, unless they have been given supervision or instruction concerning use of the appliance by a person responsible for their safety.
- Never carry out flammable cooking under the appliance
- The exhaust from the range hood must not be discharged into any heating flue, which may carry combustion products from other sources.

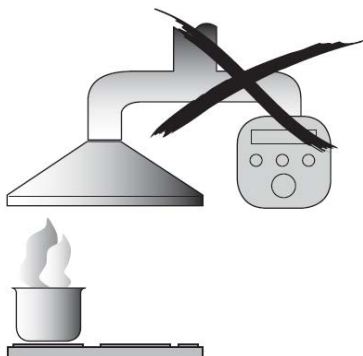

- Do not leave lit gas burners exposed due to the risk of fire.



- This range hood is not recommended for barbecues.

Always to do:

- Packaging materials (eg; polystyrene and plastic items) must be kept out of reach of babies or young children at all times due to risk of suffocation.
- Children should be supervised to ensure that they do not play with the appliance;
 - do not flambé under the range hood.;
 - CAUTION: Accessible parts may become hot when used with cooking appliances
- Ensure the range hood is switched off before carrying out maintenance, to avoid any possibility of electric shock.
- Grease filters must be removed every four weeks (maximum) for cleaning to reduce the risk of fire.
- There must be adequate ventilation of the room when the range hood is used at the same time as appliances burning gas or other fuels.
- Always cover lit gas burners with pots or pans when range hood is in use.
- Always switch off gas burners before you remove pots or pans.
- If the supply cord is damaged, the cord must be replaced by the manufacturer, its service agent or similarly qualified persons in order to avoid a hazard
- Plug must be accessible after installation.

Safety Instruction

Never to do:

- This range hood cannot be installed for outdoor use.
- It is prohibited to fit the range hood over a solid fuel stove
- This appliance must not be connected to a chimney or vent flue which is in use.
- This appliance is not to be vented into the roof cavity, must exit into open air.
- Exhaust air must not be discharged into a wall cavity, unless the cavity is designed for the purpose.
- This appliance should not be connected to ducting which ventilates rooms with fire places.

Always to do:

- Attention should be given to ensure that any applicable regulations concerning discharge of exhaust air are fulfilled.
- This appliance should be installed and maintained by a suitably qualified and competent person in accordance with the relevant safety regulations.

Before connecting the appliance to the mains supply, ensure that the voltage and frequency details on the rating plate are consistent with the source of supply.



This product must not be disposed together with domestic waste. This product has to be disposed at an authorised place for recycling of electrical and electronic appliances.

By collecting and recycling waste, you help save natural resources, and make sure the product is disposed in an environmental friendly and healthy way.



Product Description

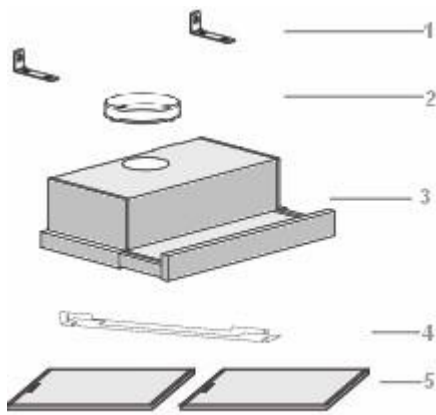

Accessories bag		
Description	Picture	QTY
Installation & User Manual		1
Metal plate		1
L bracket		2
Outlet(diameter 120mm)		1
Dry wall anchors plugs		4
Screw (M4x10mm)		2
Screw(ST4x30mm)		4
Screw (ST3x12mm)*		2
Washer*		6
Screw (M4x35mm)*		6

*Used in installation method B

Component list:

1. L bracket(used installation A method)
2. Outlet(diameter 120mm)
3. Main body
4. Metal plate(used installation B method)
5. Grease mesh filters

Technical data:

Power supply: 220 – 240v, 50Hz
 Motor: 1x100W
 Lights: 1x2W LED light Length
 of power cord: 1.70 M Air
 outlet diameter: 120mm

Operation Mode

Your range hood can only be operated in ducting mode (Air Extraction).

Air Extraction

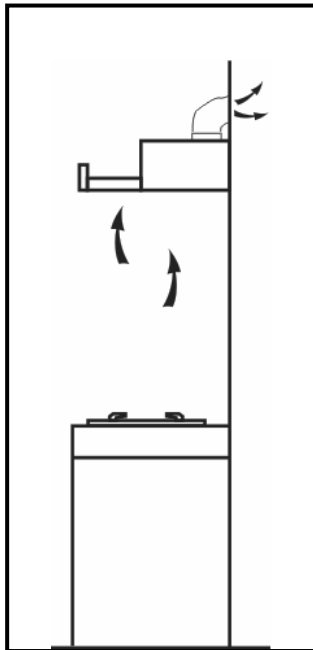

For air extraction mode, a ducting kit is required, the air is drawn in and cleaned by the grease filters and directed outside.

Ducting must be vented to outside atmosphere.

Installation

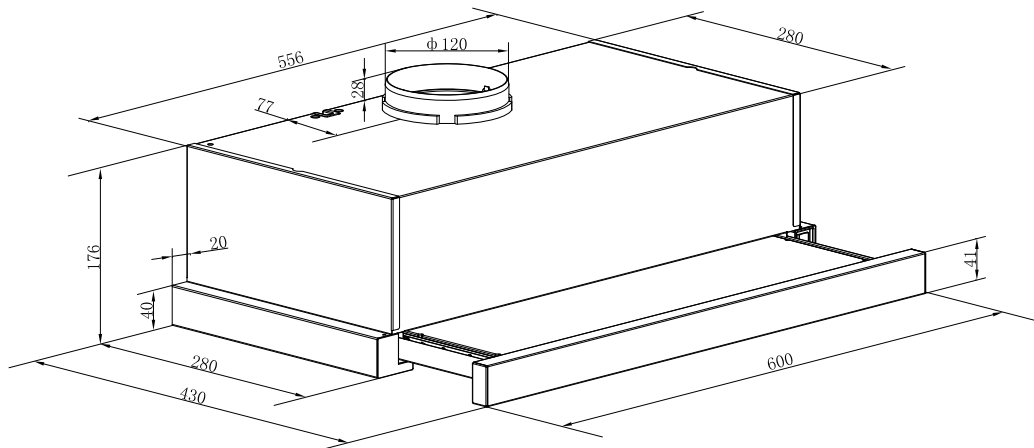

Installation:

Warning:

Check that the installation complies with the standards of local building, gas and electrical authorities. Before connecting to the mains supply ensure the mains voltage corresponds to the voltage on the appliance rating plate inside the range hood.

When installing the range hood, make sure you adhere to the minimum and maximum distances from the range hood base to the cooktop hob surface.

Hints for exhaust duct installation

The following rules must be strictly followed to obtain optimal air extraction

- Keep exhaust duct short and straight
- Do not reduce the size or restrict exhaust duct
- When using flexible duct always install the duct pulled taut to minimize pressure loss
- Failure to observe these basic instructions will reduce the performance and increase noise levels of the range hood

Ensure the exhaust ducting selected for installation complies with relevant standards and is fire retardant.

We provide two options to install your range hood, against wall (method A) or into cabinet (method B), choose what kind of method you want and then follow up corresponding instruction.

A: Install against wall

- Using a spirit level mark a vertical centre line on the wall where the hood is to be positioned, and a horizontal line where the hood base will be.

NOTE: The distance from the horizontal line to an electrical cooktop underneath must be minimum of 600mm & 650mm to a gas cook top and a maximum height of 750mm.

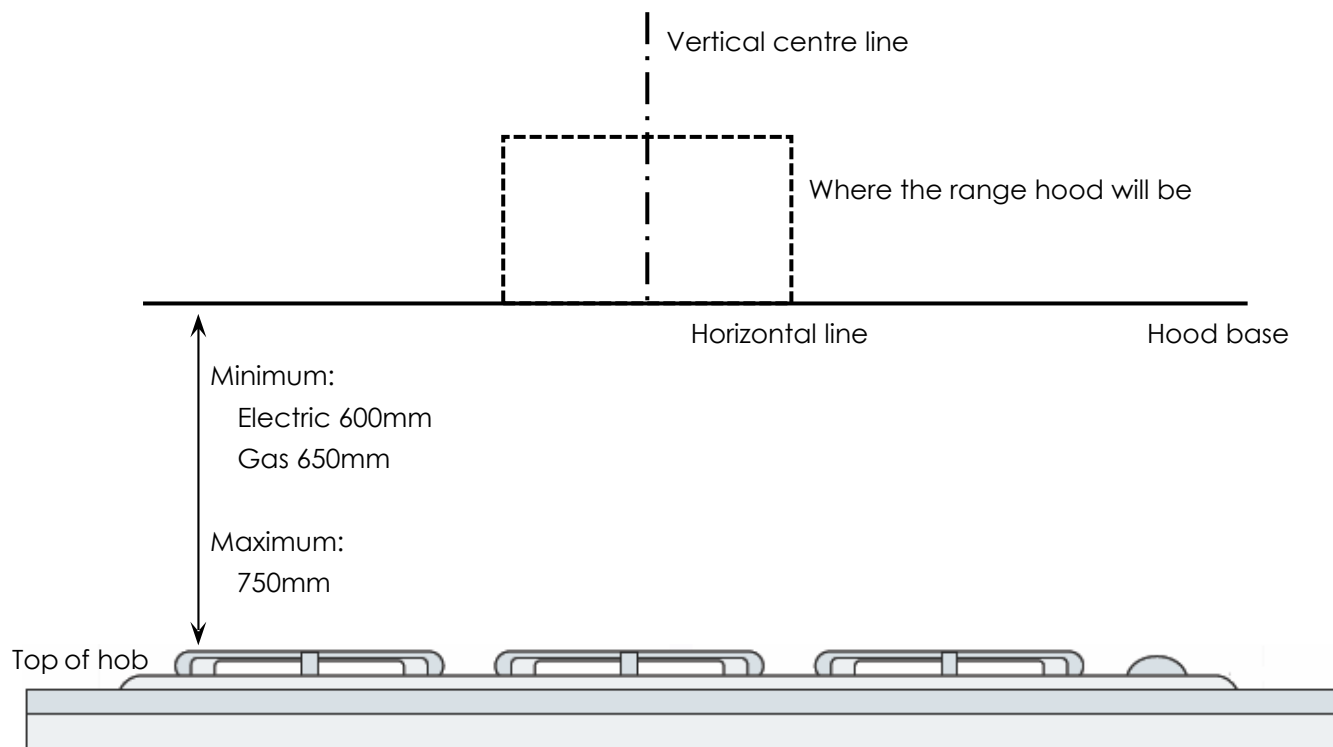

*If the instructions of the hob specify a greater distance than the minimum above, then that shall be the minimum height for installation

- Drill 4 holes of 8mm diameter on the wall according to below drawing.

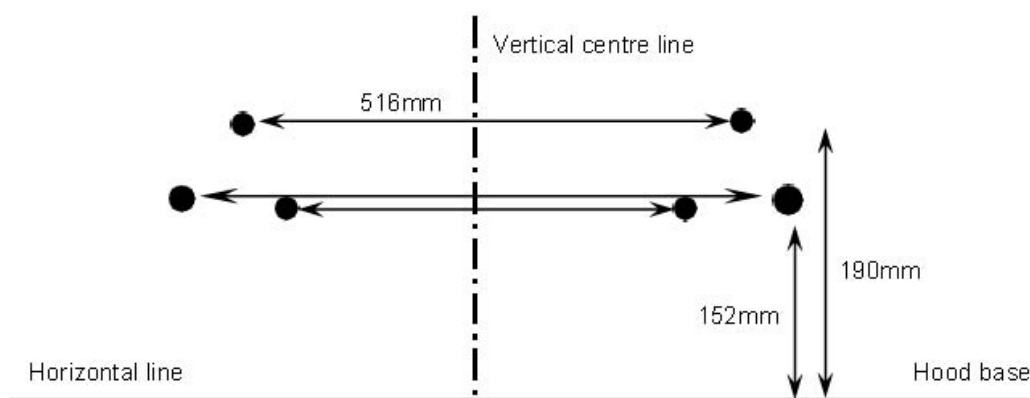

- Hammer *dry wall anchor plugs* into holes. Insert 2pcs Screw(ST4x30mm) into the two lower holes(with distance to horizontal line 496mm) and fasten, they will be used to hang on the range hood.

Warning: Failure to install the screws or fixing device in accordance with these instructions may result in electrical hazards

Fit the *outlet* and flexible exhaust pipe on top of range hood body.

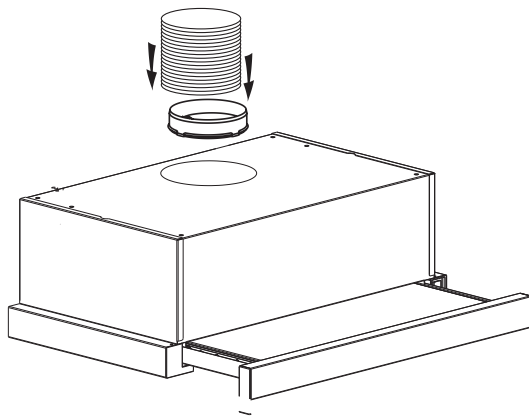

- 4 Hang on the range hood, fasten 2pcs Screw (ST4x30mm) and L bracket onto two higher holes (with distance to horizontal line 516mm), and then fasten 2pcs Screw (M4x10mm) and L bracket onto body.

Warning: Failure to install the screws or fixing device in accordance with these instructions may result in electrical hazards

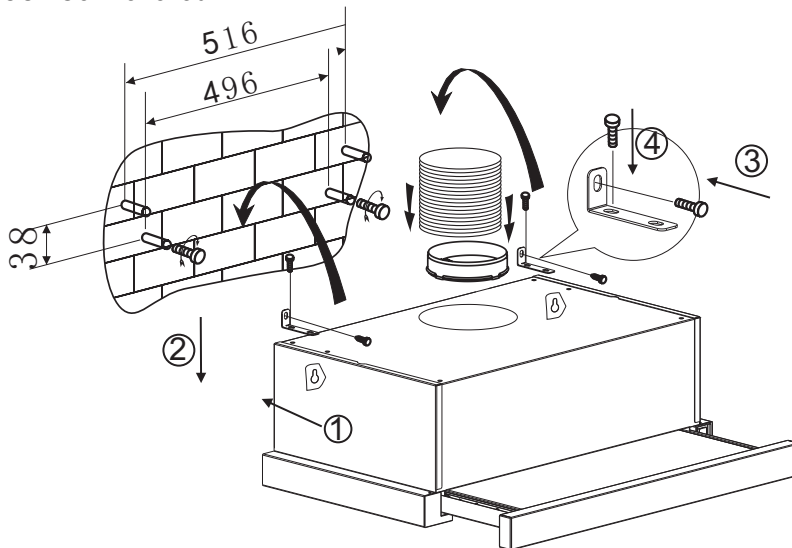

B: Install into cabinet

1. According to below drawing to determine where want to place the range hood, and drill 6 holes with 4mm diameter at the hanging board of your cabinet.

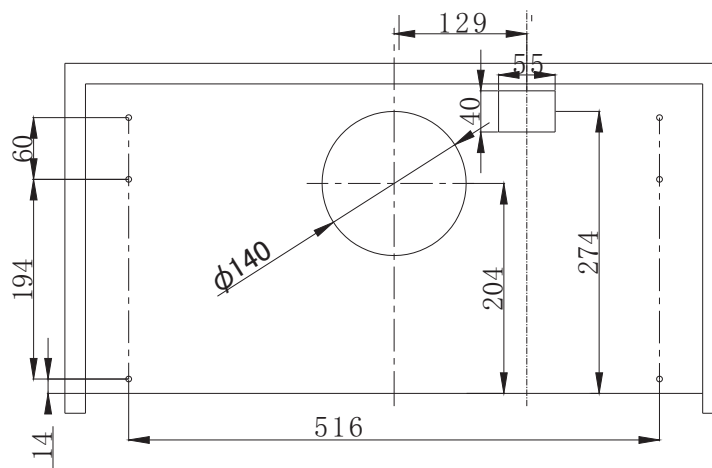

2. Fit the *outlet* on top of range hood body.
3. Install the range hood onto the bottom of cabinet board, fasten 6pcs Screw (M4x35mm) with washers. If gap is there between range hood back and cabinet end, fasten 2pcs Screw (ST3x12mm) and metal plate onto body to fill it.

Warning: Failure to install the screws or fixing device in accordance with these instructions may result in electrical hazards

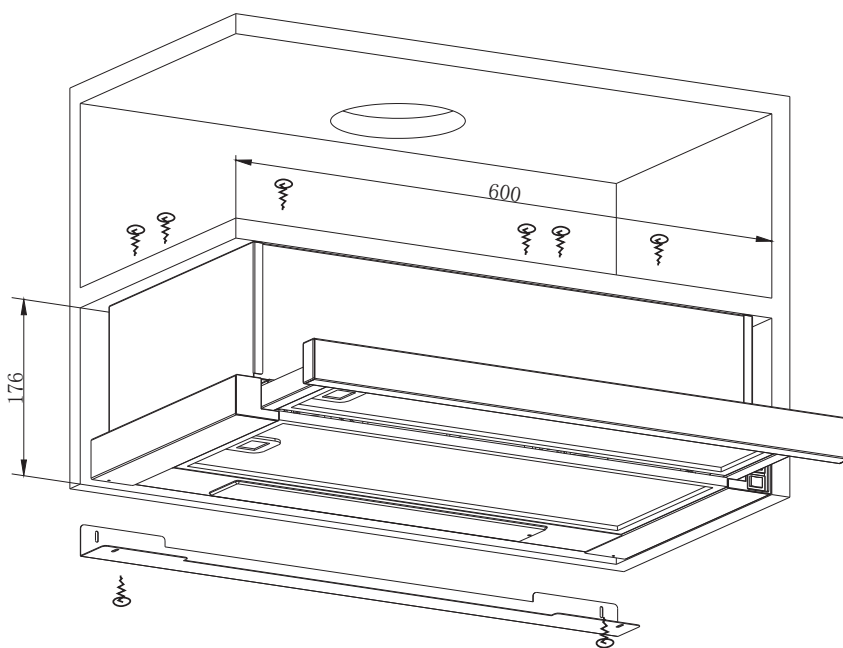

Installation of charcoal filters

Charcoal filter is optional accessory. The installation procedure of activated carbon filter is as below.

1. Remove grease mesh filters.
2. Follow up below instruction you can remove or install charcoal filters.

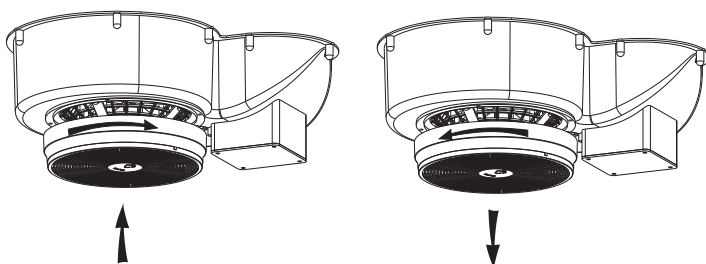

Start Using Your Range

Rocker switch

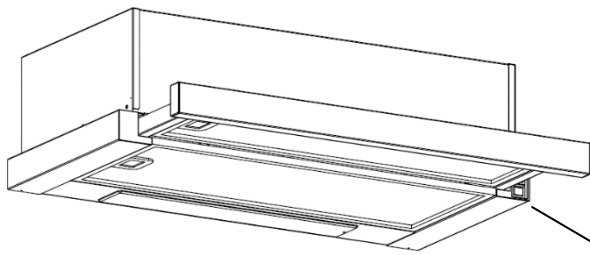

Rocker switch

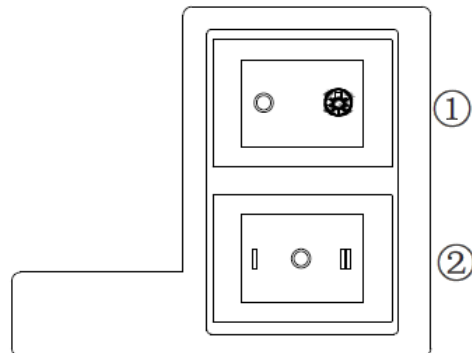

1. Insert the power plug into the socket.
2. Push switch ① to "⚙️", the lamp will be on; push switch ① to "0", the lamp will be off.
3. Push the switch ② into "I, II", the motor will be on "low, high" two speeds, push into "0", the motor will be off.
4. The power will be connected when pull out the front panel. Conversely, the power will be automatically disconnected.

Maintenance and cleaning

Caution:

- Before maintenance or cleaning is carried out, the range hood should be disconnected from the main power supply. Ensure that the range hood is switched off at the wall socket and the plug removed.
- External surfaces are susceptible to scratches and abrasions, so please follow the cleaning instructions to ensure the best possible result is achieved without damage.

GENERAL

Cleaning and maintenance should be carried out with the appliance cold especially when cleaning. Avoid leaving alkaline or acid substances (lemon juice, vinegar etc.) on the surfaces.

STAINLESS STEEL

The stainless steel must be cleaned regularly (e.g. weekly) to ensure long life expectancy. Dry with a clean soft cloth. A specialized stainless steel cleaning fluid may be used.
NOTE: Ensure that wiping is done along with the grain of the stainless steel to prevent any unsightly crisscross scratching patterns from appearing.

CONTROL PANEL SURFACE

The inlay control panel can be cleaned using warm soapy water. Ensure the cloth is clean and well wrung before cleaning. Use a dry soft cloth to remove any excess moisture left after cleaning.

Important

Avoid using harsh cleaning chemicals, strong household detergents or products containing abrasives as this will affect the appliance appearance and potentially remove any printing of artwork on the control panel and will void manufactures warrantee

GREASE MESH FILTERS

The mesh filters can be cleaned by hand. Soak them for about 3 minute in water with a mild detergent and then brush it gently with a soft brush. Do not apply too much pressure so as to avoid any damage to it .
(Leave to dry naturally out of direct sun light)

Filters should be washed separately to crockery and kitchen utensils. It is advisable not to use rinse aid.

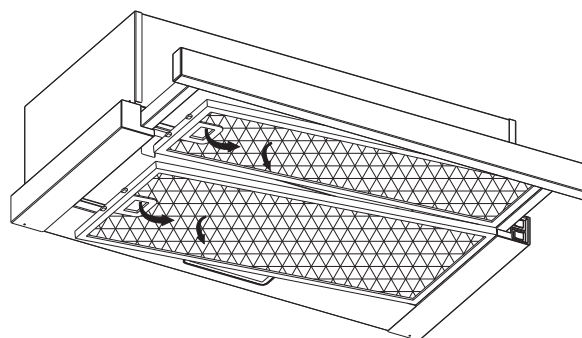

INSTALLING GREASE MESH FILTERS

To install filters for the following four steps;

- Angle the filter into the slots at the back of the hood.
- Put the button on the handle of the filter.
- Release the handle once the filter fits into a resting position.
- Repeat to install all filters.

LED LIGHT ASSEMBLY REPLACEMENT

<p>Important:</p> 	<ul style="list-style-type: none"> ✦ The light must be replaced by the manufacturer, its service agent or similarly qualified persons. ✦ Always switch off the electricity supply before carrying out any operations on the appliance. When handling the light, make sure it has completely cooled down before any direct contact to hands. ✦ When handling the light hold with a cloth or gloves to ensure perspiration does not come in contact with the light as this can reduce the life of the light.
--	---

Note:

- Before changing the lights, make sure that the appliance is turned off and unplugged.
- Protect against danger when changing lights, such as wearing gloves.

Changing the lights:

- (1) Switch off the appliance and unplug it.
 - (2) Slide the front part of the cooker hood.
 - (3) The al filter should be detached first. Press the lock and pull it downward.(4)
- Replace with same type of light.

- ILCOS D code for this lamp is: DBS-2/65-H-120/33
- LED modules –rectangle lamp
- Max wattage: 1×2 W
- Voltage range: AC 110-240V
- Dimensions:

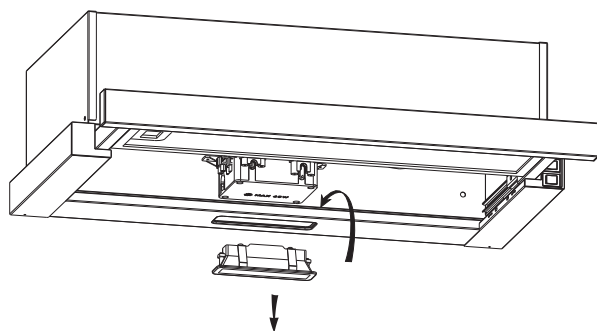
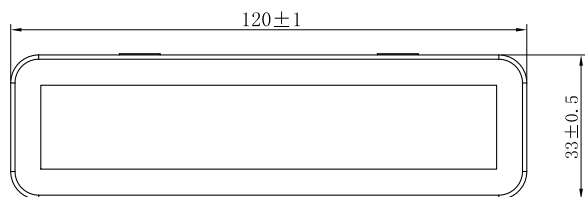

WARRANTY

- 1.1 In this warranty:
- 1.1.1 Australian Consumer Law means the law as set out in Schedule 2 of the Competition and Consumer Act 2010;
 - 1.1.2 **Company** means GSM Retail Australia Pty Ltd ABN 53 007 682 475 of 142-144 Fullarton Road, Rose Park SA 5067. Telephone 1300 373 199. Email admin@gsmretailgroup.com;
 - 1.1.3 **Consumer** means a “consumer” as that term is defined in Section 3 of the Australian Consumer Law as the original purchaser of a Mistral product;
 - 1.1.4 **Consumer Guarantees** means the guarantees under the Australian Consumer Law;
 - 1.1.5 **You** means the Consumer.
- 1.2 Nothing in this warranty affects any person’s rights under the Australian Consumer Law. The benefits to any Consumer under this warranty are in addition to the rights and remedies available under any Consumer Guarantees.
- 1.3 Subject to the other clauses of this warranty, the Company warrants to the Consumer that the Mistral product will be free of manufacturing defects and will perform to the Company’s specifications.
- 1.4 The benefit of this warranty extends only to the Consumer as original purchaser of a Mistral product which is installed in a domestic household area.
*The in Home warranty does not apply to Commercial and or industrial usage. *Please See 1.7.7 for additional information
- 1.5 This warranty commences on the date of purchase of the Mistral product by the Consumer and continues for the benefit only of the Consumer until the expiry of Two (2) year **(Warranty Period)**
- 1.6 If within the Warranty Period a manufacturing defect is discovered in the Mistral product or it fails to perform to the Company’s specifications as a result of some defect in materials, components or workmanship (Defect) then the Company will, at its option, repair the Mistral product or supply a replacement Mistral product free of charge. A replacement Mistral product may differ from the original product purchased by the Consumer.
- 1.7 This warranty will not apply to any Mistral product:
- 1.7.1 Installed by any person other than a qualified tradesperson; or
 - 1.7.2 Subjected to misuse, neglect, negligence or accidental damage; or
 - 1.7.3 Operated in any way contrary to any operating or maintenance instructions; or
 - 1.7.4 Improperly handled, installed or maintained; or
 - 1.7.5 Altered or modified prior to or after installation; or
 - 1.7.6 Damaged directly or indirectly by power surges, electrical storm damage or connection to incorrect power supply
 - 1.7.7 Industrial and or Commercial usage is inclusive of staff areas in office/ shop environments, hotel/ motel or other similar accommodation or rental type properties including Bed and Breakfast establishments.

The Australian Consumer Law requires the inclusion of the following statement with this warranty:

Our goods come with guaranteed that cannot be excluded under the Australian Consumer Law. You are entitled to a replacement or refund for a major failure and for compensation for any other reasonably foreseeable loss or damage. You are also entitled to have the goods repaired or replaced if the goods fail to be of acceptable quality and the failure does not amount to a major failure.

- 1.8 You must provide proof of your purchase of the Mistral product and the date of purchase in order to obtain the benefit of this warranty.
- 1.9 If you live outside the service area of the Company or one of its service agents, this warranty does not cover the cost of transport of the Mistral product for service nor the service agent's traveling costs to and from your home.
- 1.10 If you are required to transport the Mistral product to the Company or its service agent, you must ensure it is safely disconnected by a qualified tradesman and securely packed and insured. The Company does not accept any responsibility for loss or damage of the Mistral product prior to it being received by the Company or its service agent.
- 1.11 You will be responsible for all costs of returning a Mistral product to the Company and for redelivery of the Mistral product by the Company (whether it is the original or a repaired and/or a replacement Mistral product) and for any other expenses you incur in claiming under this warranty.
- 1.12 The Company or its service agent will examine any Mistral product and if the Company determines that it is defective through no fault of the Owner and is otherwise undamaged, the Company will repair or replace the Mistral product in accordance with this warranty.

DO NOT SEND IN THIS WARRANTY

Fill out the following details and file with your purchase invoice.

RETAIN & FILE WITH YOUR RECEIPT

Your Purchase Receipt/Invoice is proof of date of purchase. If you are unable to establish the date of purchase, or if the fault is not covered by this warranty, or if the product is found to be in working order, you will be required to bear all service call charges.

GSM Retail Australia Pty Ltd reserves the right to discontinue items, modify designs and change specifications without incurring obligation.

Whilst every effort is made to ensure that descriptions, specifications and other information in this publication is correct, no warranty is given in respect thereof and the company shall not be liable for any errors therein.

Purchased from:

Co. Name:

Address:

Date of Purchase:

Serial number:

NOTE: Consistent with our continuing product development policy, improvements may have been made which render the contents of this packaging slightly different to that shown.

**For Warranty and technical queries: Australia 1300 373 199
: New Zealand 0800 764 912**

