

# mīstral

## 60cm 9 Function Built-in Oven



## Instruction Manual

Model: MBO637-9B & MBO637-9B-F

v1 October 2025

# Thank you.

When you step up to a Mistral product, you can rest assured you're making the better choice. Because when you buy a Mistral product you're buying a brand Australian Households have trusted since 1968.

This Mistral appliance carries a 3 year in home warranty, be sure to retain your user manual and receipt.

For all warranty and technical queries please phone:

**AUS: 1300 373 199**

**NZ: 0800 764 912**



# mīstral

## Contents

<b>Safety Warnings</b>	<b>2</b>
<b>Installation</b>	<b>5</b>
<b>Prior to start up of the appliance</b>	<b>6</b>
<b>Your New Oven</b>	<b>7</b>
Oven Review	7
Technical Specifications	7
Electrical principle diagram	8
Accessories	8
Control panel	9
Digital Timer	9
<b>Function Selector</b>	<b>12</b>
Before using the oven for the first time	12
<b>How to Operate the Oven</b>	<b>13</b>
<b>Troubleshooting</b>	<b>14</b>
Maintenance and Cleaning	15
<b>Test Dishes</b>	<b>17</b>
<b>Environmental Note</b>	<b>18</b>
<b>Transportation</b>	<b>18</b>
<b>Notes</b>	<b>19</b>

### NOTE:

- Reviewing the section on Troubleshooting Tips will help you solve some common problems by yourself.
- If you cannot solve the problems by yourself, please ask for help from a professional technician.
- The manufacturer, following a policy of constant development and updating of the product, may make modifications without giving prior notice.
- If lost or out-of-date, you can receive a new user manual from the manufacturer or responsible vendor.

# Safety Warnings

This User Instruction Manual contains important information, including safety & installation points, which will enable you to get the most out of your appliance. Please keep it in a safe place so that it is easily available for future reference; for you or any person not familiar with the operation of the appliance.

These instructions shall also be available in an alternative format, e.g. on a website or on request from the user in a format such as a DVD.

## Warning:

---

- The appliance and its accessible parts become hot during use. Care should be taken to avoid touching heating elements.
  - Children less than 8 years of age shall be kept away unless continuously supervised.
  - This appliance can be used by children aged from 8 years and above and persons with reduced physical, sensory or mental capabilities or lack of experience and knowledge or they have been given supervision or instruction concerning use of the appliance in a safe way and understand the hazards involved. Children shall not play with the appliance. Cleaning and user maintenance shall not be made by children without supervision.
  - A steam cleaner is not to be used.
  - Accessible parts may become hot during use. Young children should be kept well away when in use.
  - Do not use harsh abrasive cleaners or metal scrapers to clean the oven door glass as this can scratch the surface, which may result in the oven glass shattering.
  - Do not use abrasive products to clean the glass door panel to avoid scratching it. Otherwise, severe failure might happen to the appliance.
  - The appliance must not be installed behind a decorative door in order to avoid overheating.
  - The air must not be discharged into a flue that is used for exhausting fumes from appliances burning gas or other fuels.
- Never store or use corrosive chemicals, vapors, flammables or nonfood products in or near oven. It is specifically designed for use when heating or cooking food. The use of corrosive chemicals in heating or cleaning will damage the appliance and could result in injury
  - If food inside an oven should ignite, keep door closed. Switch off the oven and disconnect from supply power.
  - Exercise caution when opening the door. Standing to the side, open the door slowly and slightly to let hot air and/or steam escape. Keep your face clear of the opening and make sure there are no children or pets near the oven. After the release of hot air and/or steam, proceed with your cooking. Keep doors closed at all time unless necessary for cooking or cleaning purposes.
  - Only use utensils that are suitable for use with ovens.

## Warning! Danger of explosion!

- Liquids and other foods must not be heated in sealed containers since they are liable to explode.
- If smoke is observed, switch off the oven and keep the door closed in order to stifle any flames.
- Do not allow any accessories or electric cables to contact the hot parts of the appliance.

## Warning! Hot surfaces! Risk of burns!

- During use the appliance becomes hot. Care should be taken to avoid touching heating elements inside the oven.
- Warning! Accessible parts may become hot during use. Young children should be kept away.
- Never move racks or pans when they are hot. Wait until they cool.

## Safety Advice: Important!

---

Always switch off the electricity supply at the mains during installation and maintenance.

## General Information

- This appliance is designed for domestic household use and can be built into a standard kitchen cabinet or housing unit.
- IMPORTANT: The adjacent furniture or housing and all materials used in the installation must be able to withstand a minimum temperature of 85°C above the ambient temperature of the room it is located in, whilst in use.

## Operation:

---

### Warning! Danger of fire!

- Do not allow paper or cloth to come in contact with any heating element.

- Certain types of vinyl or laminate kitchen furniture are particularly prone to heat damage or discolouration at temperatures below the guidelines given above.
- The appliance surfaces will become hot during use and retain heat after operation.
- Any damage caused by the non-compliance of temperature tolerance of oven during installation or by the too close distance between the furniture and the oven will be borne by the owner.
- This appliance is not intended for use by persons (including children) with reduced physical sensory, or mental capabilities, or by those who lack experience and knowledge, unless they have been given supervision and instruction concerning the use of the appliance by a person responsible for their safety .

## Installation

The oven must be installed in accordance with the installation instructions and all measurements must be followed.

All installation work must be carried out by a competent person or qualified electrician.

## Children

Please dispose of the packaging material carefully. Packaging material can be dangerous to children.

Make sure to keep children away from the appliance, children should be supervised to ensure that they do not play with the appliance. It might be dangerous to allow the children to touch the appliance.

## General Safety

Do not place heavy objects on the oven door or lean them on the oven door when it is open, as it may cause damages to the oven door hinges.

Do not place those baked hot oil or fat unattended on unattended areas, as it will be a fire risk.

Do not place pans or baking trays directly on the base of the oven cavity, even if aluminum foil is placed below them.

Do not allow cable or plug to come into contact with the heating areas of appliance.

Do not install the appliance next to curtains or soft furnishings.

Do not attempt to lift or move cooking appliances by using the oven door or handle, as this may cause damage to the appliance or result in injury to the person lifting the appliance.

## Electrical safety

- If the supply cord is damaged, it must be replaced by the manufacturer, its service agent or similarly qualified persons in order to avoid a hazard.
- The appliance must be placed in such a way, that the power supply is accessible at all times.
- Before connecting the appliance to the power supply, check that the power supply voltage and current rating corresponds with the power supply details shown on the appliance rating label.
- Never use a damaged appliance! Disconnect the appliance from the power source and contact your supplier if it is damaged.
- Danger of electric shock! Do not attempt to repair the appliance yourself. In case of malfunction, repairs are to be conducted by qualified personnel only.
- To avoid damaging the cord, do not squeeze, bend or chafe it on sharp edges. Keep it away from hot surfaces and open flames as well.
- Lay out the cord in such a way that no unintentional pulling or tripping over it is possible.
- Do not open the appliance casing under any circumstances. Do not insert any foreign objects into the inside of the casing.
- Never use accessories which are not recommended by the manufacturer. They could pose a safety risk to the user and might damage the appliance. Only use original parts and accessories.
- Keep the appliance away from any hot surfaces and open flames. Always operate the appliance on a level, stable, clean and dry surface. Protect the appliance against heat, dust, direct sunlight, moisture, dripping and splashing water.
- Do not place objects with open flames, e.g. candles, on top of or beside the appliance.
- **WARNING:** Ensure that the appliance is switched off before replacing the lamp to avoid the possibility of electric shock.
- The fixed wiring for applicant shall have an all-pole disconnection device.

## Safety:

---

- Attention, the glass is extremely fragile. Always wear gloves when handling.
- For your safety, this product is made of tempered glass. This type of glass is highly resistant but has the feature to retain the "memory" of shocks.
- Therefore, it should handle the product with the greatest care to avoid shocks and twists, especially during installation.

- Avoid installing this type of product in areas where it would be highly exposed to shocks.
- Do not let children play with the product.
- Do not stick adhesive film on the glass surface. In case of breakage, it would generate large pieces that could be dangerous

## Electrical connection

---

### Danger of electric shock!

- Any electrical installation must be carried out by an authorised professional.
- All fittings must be installed by a competent person in accordance with local regulations. If in doubt, consult a qualified electrician.
- Important! Always switch off the electricity supply at the mains during installation and maintenance. We recommend that the fuse is withdrawn or circuit breaker switched off at the distribution board whilst work is in progress.
- This product must be earthed – if no earth feed wire is available, consult an electrician.
- Means for disconnection must be incorporated in the fixed wiring in accordance with the wiring rules. To achieve this install appropriate switched fused connection unit.
- Note! A switched fused connection unit having a contact separation of at least 3mm in all poles should be connected in fixed wiring.
- Connect the incoming positive, neutral and earth cables to the terminals of the switched fused connection unit. Ensure connections are tight.

- The spur outlet must still be accessible even when your oven is located in its housing to enable the appliance to be disconnected from the mains supply.

### Cleaning

- Always disconnect the power supply prior to cleaning the appliance. If the switched fused connection unit is difficult to reach, shut off the power supply by using the corresponding circuit breaker at the distribution board.
- Clean the appliance thoroughly before first use. The oven should be cleaned regularly and any food deposits removed.
- Never clean the oven surfaces by steam cleaning.
- The oven cavity should only be cleaned with warm soapy water, using either a sponge or soft cloth. No abrasive cleaners should be used.
- Any stains that may appear on the bottom of the oven will have originated from food splashes or spilt food, these splashes occur during the cooking process. These could possibly be a result of the food being cooked at an excessively high temperature or being placed in cookware that is too small.
- You should select a cooking temperature and function that is appropriate for the food that you are cooking. You should also ensure that the food is placed in an adequately sized dish and that you use the drip tray where appropriate.

# Installation

The appliance should be installed built in the cabinet . It should be keep safety distance with appliance and the kitchen walls. Detail please check below picture (values in mm).

- Surfaces, synthetic laminates and adhesives used must be heat resistant (100°C minimum), and neighboring unit fronts up to 70°C.
- Kitchen cabinets must be set level and fixed. A gap of 5 mm is required between the appliance and surrounding unit fronts.
- If there is a drawer beneath the oven, a shelf must be installed between oven and drawer.

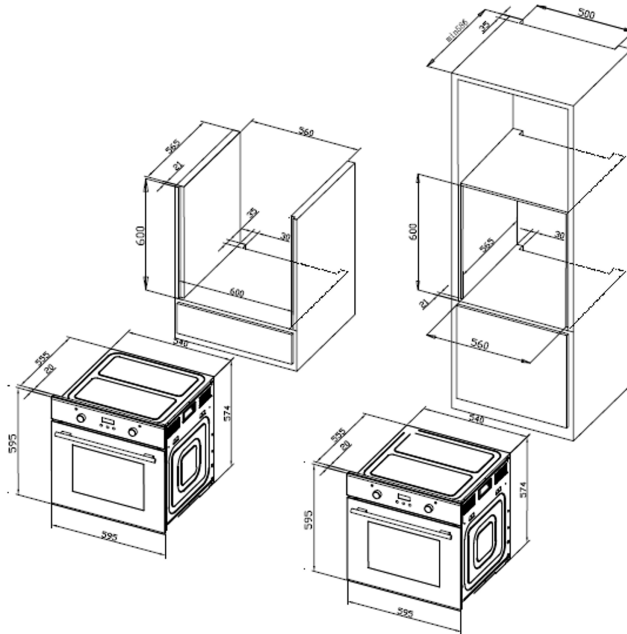

Installation method 1

Installation method 2

## Installation and connection

**!** Material damage!

- The door and/or handle must not be used for lifting or moving the appliance.
- For installation the appliance must be connected in accordance with all local gas and/or electrical regulations.
- Carry the appliance with at least two persons.
- Use the slots or wire handles located at both sides to move the appliance.

## Connection to the mains supply

This appliance must be earthed!

- Our company shall not be held responsible for any damage caused by using the appliance without an earthed socket. Risk of electric shock, short circuit or fire by unprofessional installation! The appliance may be connected to the mains supply only by an authorized qualified person and the appliance is only guaranteed after correct installation.
- Risk of electric shock, short circuit or fire by damage of the mains lead! The mains lead must not be clamped, bent or trapped or come into contact with hot parts of the appliance. If the mains lead is damaged, it must be replaced by a qualified electrician.
- The mains supply must correspond to the data specified on the rating plate of the appliance. The appliance mains cable must correspond to the specifications and the power consumption.

### **⚠ Risk of electric shock!**

Before starting any work on the electrical installation, please disconnect the appliance from the mains supply.

### Installation

1. Slide the oven through the cabinet aperture, align and secure.
2. Fix your oven with the 2 screws and washers as indicated in the figure.

### Final check

3. Connect the appliance to the mains supply and switch on the mains supply.
4. Check function.

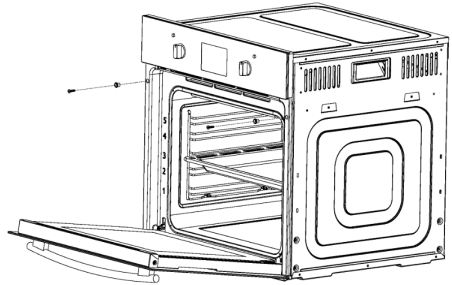

# Prior to start up of the appliance

- Once this simple operation has been carried out the oven is ready to use for cooking.
- This appliance is exclusively for domestic use.
- Use the oven to cook food only.
- Before cooking, make sure all oven accessories that are not required are removed from the oven.
- Pre-heat the oven to the cooking temperature before using it.
- Place the cooking trays in the center of oven and leave space in between when using more than one, so that the air can circulate.
- Do not put oven trays on the base of the oven or cover it with aluminium foil. This will cause thermal accumulation. The cooking and roasting times will not coincide and the enamel may be damaged.
- Try to open the oven door as little as possible to see the food (the oven light remains on during cooking).
- Take care when opening the door to avoid contact with hot parts and steam.

Remember to connect the safety circuit to the connection box terminal marked with. The electricity supply for the cooker must have a safety switch which enables the power to be cut off in case of emergency. The distance between the working contacts of the safety switch must be at least 3mm.

Before connecting the cooker to the power supply it is important to read the information on the data plate and the connection diagram.

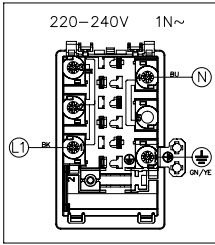
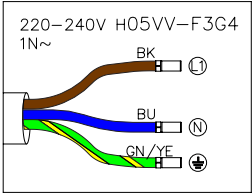
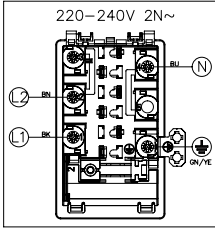
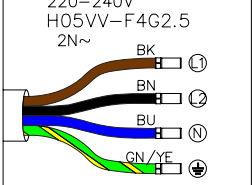
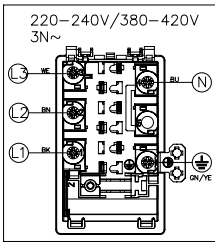
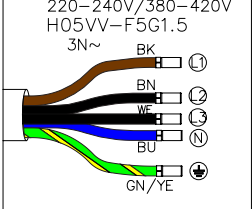
<b>CONNECTION DIAGRAM</b> Caution! Voltage of heating elements 230V Caution! In the event of any connection the earth wire must be connected to the $\oplus$ PE terminal		Recommended type of connection lead
1	For 230 V earthed one-phase connection, bridges connect 1-2-3 terminals and 4-5 terminals, earth wire to $\oplus$	220-240V 1N~  220-240V H05VV-F3G4 1N~ 
2	For 230V earthed two-phase connection, bridges connect 2-3 terminals and 4-5 terminals, the earth wire to $\oplus$	220-240V 2N~  220-240V H05VV-F4G2.5 2N~ 
3	For 400-230V earthed two-phase connection, bridges connect 4-5 terminals, phases in succession 1,2 and 3, Neutral to 4-5, the earth wire to $\oplus$	220-240V/380-420V 3N~  220-240V/380-420V H05VV-F5G1.5 3N~ 

L1=R, L2=S, L3=T, N=neutral wire terminal, PE= earth wire terminal

# Your New Oven

## Oven Review

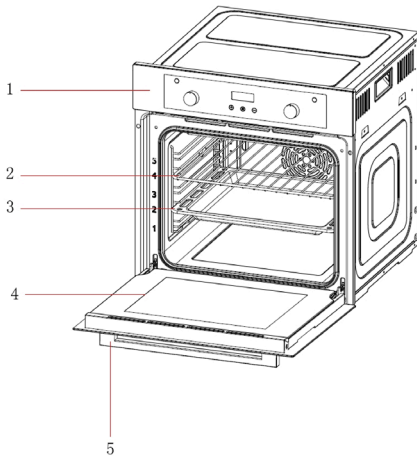

- 1. Control Panel
- 2. Wire Rack
- 3. Baking Tray
- 4. Oven Glass Door
- 5. Handle

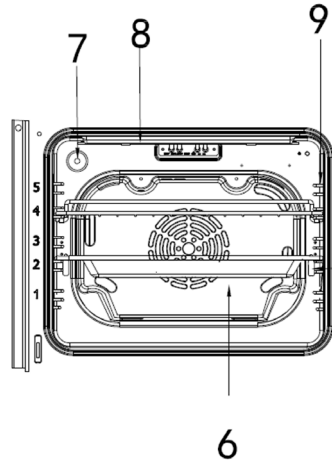

- 6. Fan motor (behind steel plate)
- 7. Lamp
- 8. Grill
- 9. Side Rack

## Technical Specifications

Voltage/frequency	220-240V~50Hz
Total power consumption	2.300KW
Cable type/section	H05VV-F 3*1.5mm <sup>2</sup>
Cable length	1.2m
External dimensions(height/width/depth)	595/595/575 (mm)
Main oven	Multifunction oven
Oven lamp	25W/300°C

# Electrical principle diagram

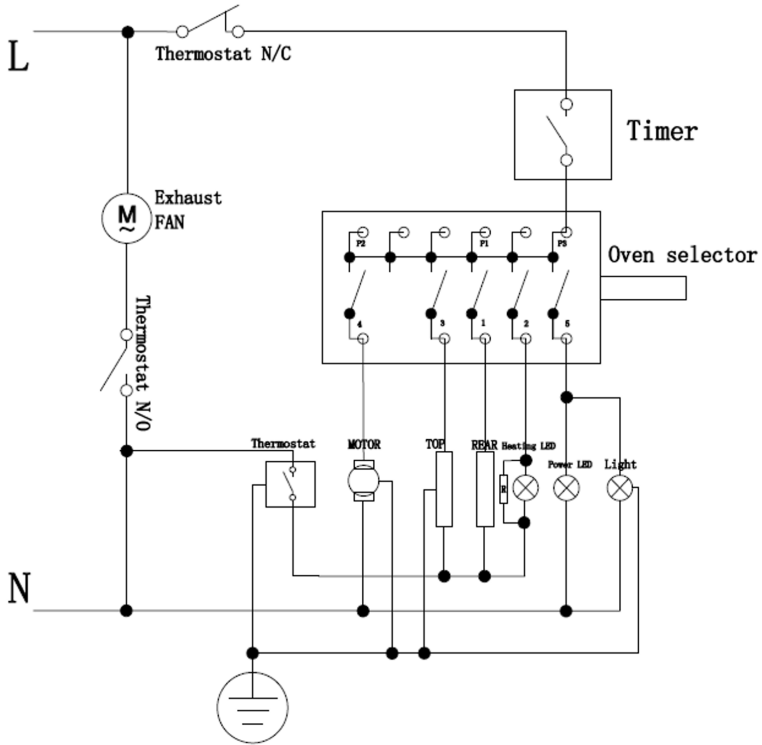

## Accessories

1. The accessories supplied with your appliance are suitable for making many meals. Ensure that you always insert the accessories into the cooking compartment the right way round.
2. There is also a selection of optional accessories, with which you can improve on some of your favorite dishes, or simply to make working with your oven more convenient.

### Inserting accessories

You can insert the accessories into the cooking compartment at 5 different levels. Always insert them as far as they will go so that the accessories do not touch the door panel.

The accessories can be pulled out approximately halfway until they lock in place. This allows dishes to be removed easily.

Note: The accessories may deform when they become hot. Once they cool down again, they regain their original shape. This does not affect their operation.

### Oven pan

For moist cakes, pastries, frozen meals and large roasts. It can also be used to catch dripping fat when you are grilling directly on the wire rack.

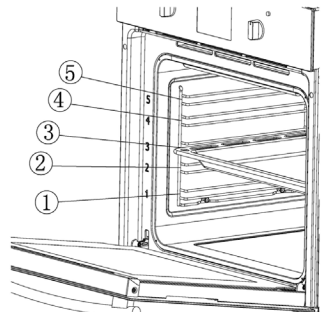

## Wire rack

Used for roasting and for placing the food to be baked, roasted or cooked in casserole dishes to the desired rack.

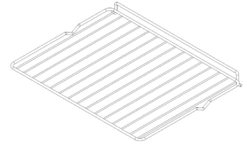

## Side shelf

①②③④⑤ on behalf of five different height positions for your choosing. For removable side shelf, you can adjust four different height positions to bake food. Used for placing grills and trays which fixed to the sides of the oven cavity.

For cooking larger, these side shelf can be removed, wire rack can be put on the oven floor, using functions as grill, full grill, full grill with fan.

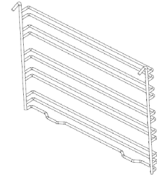

## Control panel

Here, you will see an overview of the control panel. Depending on the appliance model, individual details may differ.

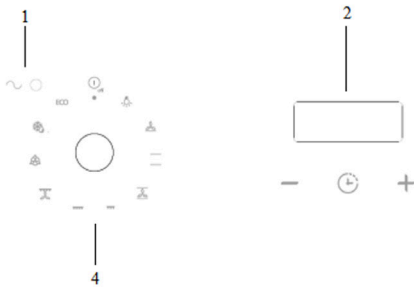

1. Power Indicator light
2. Digital Timer
3. Heating Indicator light
4. Functional Selector
5. Temperature control knob

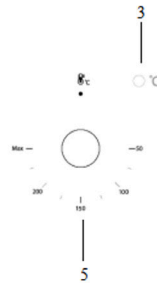

## Digital Timer

Icons	Function
—	Minus button
+	Plus button
	Program selection key

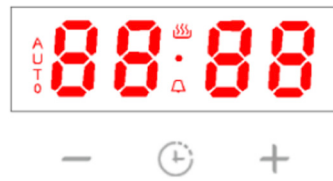

Icons	Function
1	"Auto" function symbol
2	Oven in use symbol
3	Program selection key
4	Clock symbol
5	Display the time, can display system time, clock and cooking time

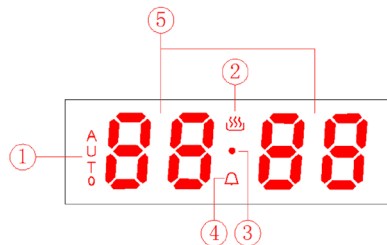

## Timer Operation Instructions

O'clock setting – You need to set up current O'clock time before timer or minute minder function.

1. When the oven connects to power supply, the buzzer beeps to indicate that the timer has entered the clock setting state.
2. The default display is "12:00", hour segment flash and waiting for adjustment, minute stay on.
3. The hour segment can be adjusted by pressing the plus + and minus – keys, hour segment ranged from 0-23. If there is no operation within 5 seconds, it automatically switches to the minute segment flashing.
4. The minute segment can be adjusted by pressing the plus + and minus – keys, minute segment ranged from 0-59.

If there is no operation within 5 seconds, it is automatically confirmed and enters the clock standby state, and the second icon ● flashes once per second.

The display effect is shown below.



(If you want to readjust the time while in clock mode, you can press both the "⌚" and "+" keys at the same time, and the hour segment will flash, the setting method is as above.)

Note: The system clock time defaults to 24-hour clock, with a setting range of 0:00 to 23:59.

## Timer Setting

### Cooking Duration Setting

1. Lightly tap the key "⌚" once when the timer is in standby mode, the minute of timer and "🕒" will flash, then enter the cooking time setting
2. When the minute and "🕒" is flashing, press "+" or "-" to set the cooking duration time. (The timer setting range is 0:00-10:00, which can be adjusted by pressing one by one or by long pressing). After setting, move your hand away and without no operation within 5 seconds, the minute and "🕒" stop flashing, and the "🕒" remains constantly on.
3. When it is necessary to adjust the timer, press the key "⌚" one time in the working state, when the minute and "🕒" flash, the previously setting time or remaining time will be displayed, and the user can adjust the timer again.

4. After the heating countdown ends, the bell rings. Touch any key to cancel the sound, or the bell will stop automatically after one minute

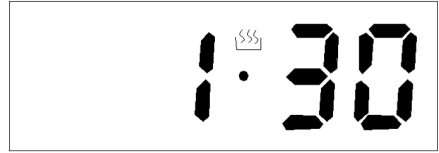

In this operating mode, the displays for scheduled oven operation and the other active timer functions change at 3-second intervals. After the heating countdown ends, the bell rings. Touch any key to cancel the sound, or the bell will stop automatically after one minute.

Note: After being powered on, if the cooking time is not set, the oven will not work

### Delayed Start Cooking Time Setting



1. Set the cooking time as described in the previous section 1.1.
2. Once both the cooking time has been set, tap the "⌚" once again, the "AUTO" and the minute will be flashing.
3. Press "+" to set the delayed start cooking time, after setting, move your hand away and without no operation within 5 seconds, the "AUTO" stop flashing. And the current time of day will be displayed.



Noted: Delayed Start Cooking time = End Time – (time of day + cooking time)

### Cooking End Time Setting

1. In standby mode, lightly tap the program selection "⌚" twice, the "AUTO" and the minute will flash, then enter the cooking end time setting.
2. Press "+" to set the cooking end time. After setting, move your hand away and without no operation within 5 seconds, the "AUTO" and the minute stop flashing. And the current time of day will be displayed.

## Alarm clock setting

In clock standby mode, lightly tap the program selection key “” three times, or in timed heating working mode, lightly tap the program selection key “” two times to enter the alarm clock setting mode.

When setting this function, the alarm icon “” flashes (as shown below), and the alarm time can be set by short or long pressing the plus key “+” and the minus key “-”. After setting, wait for 5 seconds to automatically confirm the alarm time, and the alarm icon  will stop flashing.

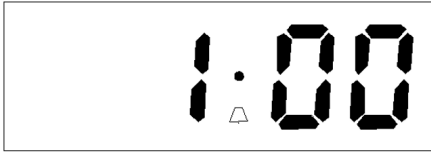



### Alarm Clock Display Interface

**Note:** Alarm time setting range: 0:00 ~23:59.

The alarm clock is an independent function. After setting, it will start counting down, and the display interface will alternate with other function interfaces every 3 seconds. After the countdown ends, the alarm will sound. Touch any key to cancel the sound, or it will automatically stop after ringing for 1 minute. Then the alarm clock display interface disappears.

## Fast timed heating

In clock standby mode, long press the program selection key “” for 3 seconds to automatically enter the default timer 2:00 countdown setting. At this time, the heating time cannot be adjusted, and the display interface is fixed on the countdown display interface during operation. If you need to cancel the fast timed heating, you can long press the program selection key “” for 3 seconds again.

## Door Control Switch Function

The door control switch detects the open/close status of the oven door. Its detection function is only activated after the timer reservation feature is enabled. When the door is detected as open, even if the reserved timing period has ended, the main relay remains disconnected until the door is closed and detected, after which the main relay will engage.

If only the heating timer is set without enabling the reservation function, the oven operates independently of the door control switch, regardless of whether the door is open or closed.

## Thermostat control knob

The oven thermostat control knob sets the required temperature of the oven. It is possible to regulate the temperature within a range of 50 - 250°C.

Turn the control knob clockwise.

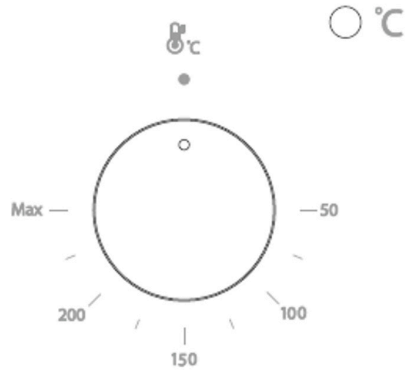

# Function Selector

Turn the function selector in any direction to set the desired function.

This appliance has 10 functions available.



**OVEN LIGHT:** This mode turns on the oven light and other electric devices do not work.



**FAN AND BOTTOM ELEMENT:** This method of cooking utilizes the bottom element in conjunction with the fan, which helps to circulate the heat. This function is suitable for sterilizing and preserving jars.

**CONVENTIONAL OVEN** (top and bottom element): This method of cooking provides traditional cooking, with heat from the top and bottom elements. This function is suitable for roasting and baking on one shelf only.



**INTENSIVE BAKE:** This method of cooking is a conventional cooking method, the oven heat from top element to bottom element, and the fan helps to circulate the heat to achieve an even baking result.

**HALF GRILL:** This method of cooking utilizes the inner part only of the top element, which directs heat downwards onto the food. This function is suitable for grilling small portions of bacon, toast and meat etc.

**FULL GRILL:** This method of cooking utilizes the inner and outer parts of the top element, which directs heat downwards onto the food. This function is suitable for grilling medium or large portions of sausages, bacon, steaks, fish etc.



**FAN AND GRILL:** This method of cooking utilizes the top element in conjunction with the fan, which helps to provide a quick circulation of heat. This function is suitable where quick browning is required and "sealing" the juices in, such as steaks, hamburgers, some vegetables etc.



**FAN FORCED:** This function turns on the rear fan and the rear heating element on. The fan helps circulate the heat throughout the oven and allows food on different rack levels to be cooked at the same time.



**DEFROST:** The fan runs without heat to reduce the defrosting time of frozen foods. The time required to defrost the food will depend on the room temperature, the quantity and type of food.

**ECO ENERGY SAVING GRILLING MODE:** This method of cooking uses the top outer ring and the bottom heating element to control the temperature, making the grilling more energy saving, mainly suitable for large food, oven temperature rises slowly, the heat fully penetrates and the excess heat consumption is reduced.

## Before using the oven for the first time

---

### Heating up the oven

To remove the new cooker smell, heat up the oven when it is empty and closed. An hour of Top/bottom heating at 250°C is ideal for this purpose. Ensure that no packaging remnants have been left in the cooking compartment.

1. Use the function selector to set Top/bottom heating.
2. Set the temperature selector to 250°C. After an hour, switch off the oven. To do so, turn the function selector to the off position.

### Cleaning the accessories

Before you use the accessories for the first time, clean them thoroughly with hot soapy water and a soft dish cloth.

### Tips for saving energy

The following information will help you to use your appliance in an ecological way, and to save energy:

1. Use dark coloured or enamel coated cookware in the oven since the heat transmission will be better.
2. While cooking your dishes, perform a preheating operation if it is advised in the user manual or cooking instructions.
3. Do not open the door of the oven frequently during cooking.
4. Try to cook more than one dish in the oven at the same time, whenever possible. You can cook by placing two cooking vessels onto the wire grill.
5. Cook more than one dish one after another. The oven will already be hot.
6. You can save energy by switching off your oven a few minutes before the cooking time. Do not open the oven door.
7. Defrost frozen dishes before cooking them.

# How to Operate the Oven

General information on baking, roasting and grilling

Risk of scalding by hot steam! Take care when opening the oven door as steam may escape.

## Tips for baking

1. Use non-stick coated appropriate metal plates or aluminum containers or heat-resistant silicone moulds.
2. Make best use of the space on the rack.
3. It is recommended to place the baking mould in the middle of the rack.
4. Keep the oven door closed.

## Tips for roasting

Seasoning with lemon juice and black pepper will improve the cooking performance when cooking a whole chicken, turkey or a large piece of meat.

Meat with bones takes about 15 to 30 minutes longer before it is cooked than a roast of the same size without bones.

You should calculate about 4 to 5 minutes cooking time per centimeter height of the meat.

Let meat rest in the oven for about 10 minutes after the cooking time. The juice is better distributed all over the roast and does not run out when the meat is cut.

Fish in a fire-resistant dish should be placed on the rack at the medium or lower level.

## Tips for grilling

Grilling is ideal for cooking meat, fish and poultry and will achieve a nice brown surface without it drying out too much. Flat pieces, meat skewers and sausages are particularly suited for grilling as are vegetables with a high water content such as tomatoes and onions.

# Troubleshooting

The oven may have some abnormal breakdown during working, you can check the fault list before calling to the after-sell service, maybe some breakdown you can repair by yourself.

## Normal operation

When first using the oven, it may have some situation of peculiar smell and smoking for some hours; Open the heating pattern to let the oven burn without anything for 1 hour when use the oven for the first time, then close the heating function, waiting for some time until the oven is cold, open the door and clean the oven.

When the oven is operating, you may hear slight cracking or popping sounds caused by the metal heating and cooling.

If the heating foods have some moisture, the heating emission hole may blow steam during the working operation.

The fan starts about 15 minutes after the oven begins working and keeps running for around 35 minutes after the oven is turned off.

Please preheat before you put food in the oven when baking. When cooking for longer periods, you can switch off the oven before the end and let the residual heat complete the cooking process.

Fault	Possible Causes	Solution
Oven isn't working	Interrupt electrical current	Check your kitchen light or other appliance if working on
	Breaker malfunction	Check if your breaker are working on
	Forgot to push the timer function	Reset the timer function
Lamp isn't coming on	Lamp have defectiveness	Change for a new lamp
	No electrical current	Check if the oven have electrical current
Oven stop working in a sudden during working	Power interrupt	Check your kitchen light or other appliance whether still working on
	Normal close thermostat protective	Check if the cool fan are working, if yes, need change for a new normal close thermostat
Oven not heating	Not adjust the temperature controller	Set up the temperature
	If this model have timer, you may not set up the time	Set up the timer
	No power	Check the power box
	Heating element was damaged	Change for a new heating element
Water come out from the glass door when working	Door seal is blow-by	Change for a new door seal
	Hinge is not strong enough	Change for a new hinge
Oven stop working but the motor cool still working	Oven working for a long time, so cooling oven need for a long time	Put your hand to the outlet and feel if it is come out for hot air, if yes, it is normal
	Normal open thermostat have a problem	If the air temperature from the outlet is room temperature, need change for a new normal open thermostat

If the problem has not been solved:

1. Separate unit from the mains supply (deactivate or unscrew fuse).
2. Call the after-sales service of your store reseller; Do not attempt to repair the appliance yourself. There are no customer service items inside the appliance.

## Maintenance and Cleaning

- The oven should be cleaned after every use. When cleaning the oven the lighting should be switched on to enable you to see the surfaces better.
- The oven chamber should only be washed with warm water and a small amount of washing-up liquid.
- After cleaning the oven chamber wipe it dry.
- Never clean the oven surfaces by steam cleaning.
- The oven cavity should only be cleaned with warm soapy water, using either a sponge or soft cloth. No abrasive cleaners should be used.
- Any stains that may appear on the bottom of the oven will have originated from food splashes or spilt food, these splashes occur during the cooking process. These could possibly be a result of the food being cooked at an excessively high temperature or being placed in cookware that is too small.
- You should select a cooking temperature and function that is appropriate for the food that you are cooking. You should also ensure that the food is placed in an adequately sized dish and that you use the drip tray where appropriate.
- Outer parts of the oven should only be cleaned with warm soapy water, using either a sponge or soft cloth. No abrasive cleaners should be used.
- If you use any form of oven cleaner on your appliance, then you must check with the manufacturer of the cleaner that it is suitable for use on your appliance.
- Any damage that is caused to the appliance by a cleaning product will not be fixed free of charge, even if the appliance is within the guarantee period.
- Do not use cleaning products containing abrasive materials for the cleaning and maintenance of the glass front panel.

### Replacement of the oven light bulb

- In order to avoid the possibility of an electric shock ensure that the appliance is switched off before replacing the bulb.
- Set all control knobs to the position "0" and disconnect the mains plug, unscrew and wash the lamp cover and then wipe it dry.
- Pull out the light bulb from the socket, replace the bulb with a new one—a high temperature bulb (300°C) with the following parameters:
  - voltage 230V
  - power 25W
  - thread G9.
- Do not use any other type of bulb.

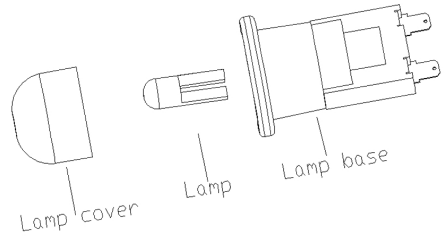

- Insert the bulb, making sure it is properly inserted into the ceramic socket.
- Screw in the lamp cover.

### Cleaning the oven

- No oven cleaner or any other special cleaning agent is required for cleaning the oven. It is recommended to wipe the oven with a damp cloth while it is still warm.
- To clean the side walls and oven door
  - Take down left and right side-shelves, method is pushing the bottom of shelves and pull to sides at the same time, push up side shelves and rotate up to level, and pull out the rack.
  - Cleaning left and right sides, order of install is opposite to the order of take down.

### Detaching and attaching the oven door

- For cleaning purposes and to remove the door panels, you can detach the oven door. Every door hinge has a locking rod, when it is closed, door was fixed in place, then the door was not disassembly. If in order to remove down door to open the locking rod, hinge will be locked and would not bite.
- When the hinge not locked, it will have a big strength to close in sudden. Make sure locking rod closed all the time, and insure it was open when remove the door.

### Remove the door

- Fully open the door.
- Fold up the right and left side of locking rod.
- Close the door until reach to stop step, hold on both left and right sides of the door, then reclose the door, upward and downward and pull out the door.

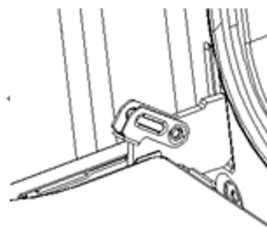

## Install the oven door

According to the opposite order of door disassembly

- When install oven door, make sure both hinge plug into opening mouth directly.
- Both sides of hinge rabbit must bite up each other.
- When open the door, spread down locking rod
- If the door drop accidentally or hinges shut up suddenly, do not push you hand in hinges. Please call your after-sell department.

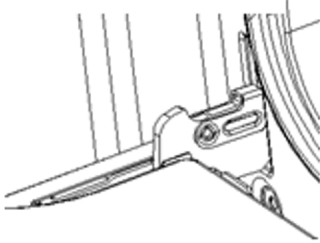

## Remove and install door panel

### Remove

- Remove oven door, put it on a piece of cloth.
- Using one hand to push the outside glass, the other hand to pull the inside glass, hold the glass then pull out the glass.
- Notice! Dangerous! If the glass has some scratches, it may lead to cracking.
- Don't use the glass spatula, acute and corrosive cleaning product or detergent to clean the glass.

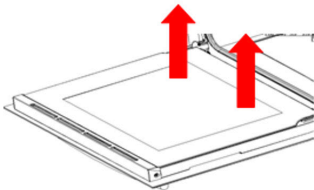

### Install

- Plug the inner glass into glass pressure groove.
- Both right and left sides need put down alignment to card slot and push the glass to its place.
- Put on the oven door.

## Remove and install side shelves

- In order to clean sides of oven, you should remove the side shelves to clean the oven
  - Downward the shelf and pull it out.
  - Lift up the side shelf to level and pull it out.
- Do not use the oven before correctly assemble the oven door.

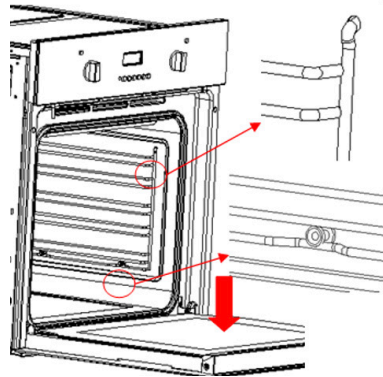

## Replacing the oven lamp

If the bulb in the oven Light fails, it must be replaced. Risk of electric shock!

- Switch off the circuit breaker in the fuse box.
- Place a tea towel in the oven when it is cold to prevent damage.
- Unscrew the glass cover by turning it anti-clockwise.
- Replace the bulb with one of the same type.
- Screw the glass cover back in.
- Remove the tea towel and switch on the circuit breaker.

## Regular inspections

- Besides keeping the cooker clean, you should:
  - Carry out periodic inspections of the control elements and cooking units of the cooker. After the guarantee has expired you should have a technical inspection of the cooker carried out at a service centre at least once every two years.
  - Fix any operational faults
- Carry out periodical maintenance of the cooking units of the cooker.

### Caution!





















All repairs and regulatory activities should be carried out by the appropriate service centre or by an appropriately authorized fitter.

# Test Dishes

We provide all kinds of recipes and ideal setting for choice here. It will show you which heating type and which temperature are of best suits for your dishes. You can find information about the appropriate accessories and its insertion height, as well as tips on cooking containers and methods of preparation.

## Instructions:

1. The values in the table can always apply to the dishes place in the cold and empty oven. Only pre-heat the oven when it states in the table below. Do not lay the oil-proof paper onto the accessories before pre-heat is completed.
2. The baking parameters given in Tables are approximate and can be corrected based on your own experience and cooking preferences.
3. Please use the accessories provided. Before cooking, check that any accessories that are not required are removed from the oven.
4. Oven glove must be used when removing the accessory or ovenware from the appliance.

Foods	Accessory	Heating function	Rack place	Temperature setting (°C)	Heating time (Mins)
Cake	Round model		2nd layer	140-160	30-45
Bread	Bake Pan		2nd layer	180-200	10-20
	Bake Pan		3rd layer	170-190	10-20
	Bake Pan		3rd +1st layer	160-180	10-20
Thin pizza (cold)	Bake Pan		2nd layer	190-210	15-25
Deep pizza (cold)	Bake Pan		2nd layer	180-200	20-30
	Bake Pan +rack		3rd +1st layer	170-190	25-35
Bread (9 piece)	Rack		3rd layer	160-170	10-15
	Rack		3rd +1st layer	160-180	15-25
Sausage	Rack		3rd layer	160-180	10-15
Ribs	Rack		3rd layer	200-220	20-35
Pork	Bake Pan		2nd layer	190-210	70-85
	Bake Pan		1st layer	180-200	55-70
Beefsteak (3cm thickness)	Bake Pan		2nd layer	190-210	20-35
Small whole chicken (1.2kg)	Rack		2nd layer	200-220	50-60
Whole chicken (1.6kg)	Rack		2nd layer	190-210	50-60
Small chicken pieces (150g)	Rack		3rd layer	200-220	30-40
Whole goose (3.5kg)	Rack		2nd layer	170-190	60-70
Big piece of mutton with bone (1.2kg)	Bake pan		2nd layer	170-190	60-70
Whole fish (1.0kg)	Rack		2nd layer	200-220	30-40
Whole fish (1.5kg)	Rack		2nd layer	180-200	40-50

# Environmental Note

Note: Before discarding an old appliance, switch off and disconnect it from the power supply. Cut off and render any plug useless. Cut the cable off directly behind the appliance to prevent misuse. This should be undertaken by a competent person.



**DISPOSAL:** Do not dispose this product as unsorted municipal waste. Connection of such waste separately for special treatment is necessary.

This appliance is marked according to the European directive 2002/96/EC on Waste electrical and Electronic Equipment (WEEE). By ensuring this product is disposed of correctly, you will help prevent potential negative consequences for the environment and human health, which could otherwise be caused by inappropriate waste handling of this product.

The symbol on the product or on the documents accompanying the product indicates that this appliance may not be treated as household waste. Instead it shall be handed over to the applicable collection point for the recycling of electrical and electronic equipment.

Disposal must be carried out in accordance with local environmental regulations for waste disposal. For more detailed information about treatment, recovery and recycling of this product, please contact your local city office or local waste management office.

The packaging materials that we use are environmentally friendly and can be recycled. Please discard all packaging material with due regard for the environment.

# Transportation

Keep the original carton of the product and use this packaging if the item needs to be transported.

Follow the transport signs on the carton.

Place a paper between the upper cover and cooling panel, cover the upper cover, then tape to the side surfaces of oven.

Tape cardboard or paper onto the inside face of the glass as it will be prone to damage from the trays. Use cardboard covers for the wire grill and trays in your oven. Also tape the oven's covers to the side walls.

If the original carton is unavailable, take measures to protect the external surfaces (glass and painted surfaces) of oven against possible blows, as well as the above.

# Notes

# Notes

# Warranty

## 1.1 In this warranty:

- 1.1.1 Australian Consumer Law means the law as set out in Schedule 2 of the Competition and Consumer Act 2010;
- 1.1.2 Company means GSM Retail Australia Pty Ltd ABN 53 007 682 475 of 142-144 Fullarton Road, Rose Park SA 5067. Telephone 1300 373 199. Email admin@gsmretailgroup.com
- 1.1.3 Consumer means a "consumer" as that term is defined in Section 3 of the Australian Consumer Law as the original purchaser of a Mistral product;
- 1.1.4 Consumer Guarantees means the guarantees under the Australian Consumer Law;
- 1.1.5 You means the Consumer.

1.2 Nothing in this warranty affects any person's rights under the Australian Consumer Law. The benefits to any consumer under this warranty are in addition to the rights and remedies available under any Consumer Guarantees.

1.3 Subject to the other clauses of this warranty, the Company warrants to the Consumer that the Mistral product will be free of manufacturing defects and will perform to the Company's specifications.

1.4 The benefit of this warranty extends only to the Consumer as original purchaser of a Mistral product which is installed in a domestic household area.  
\*The In Home warranty does not apply to Commercial and or industrial usage.\*Please See 1.7.7 for additional information

1.5 This warranty commences on the date of purchase of the Mistral product by the Consumer and continues for the benefit only of the Consumer until the expiry of !No (3) year (Warranty Period).

1.6 If within the Warranty Period a manufacturing defect is discovered in the Mistral product or it fails to perform to the Company's specifications as a result of some defect in materials, components or workmanship (Defect) then the Company will, at its option, repair the Mistral product or supply a replacement Mistral product free of charge. A replacement Mistral product may differ from the original product purchased by the Consumer.

1.7 This warranty will not apply to any Mistral product:

- 1.7.1 Installed by any person other than a qualified tradesperson; or
- 1.7.2 Subjected to misuse, neglect, negligence or accidental damage; or
- 1.7.3 Operated in any way contrary to any operating or maintenance instructions; or
- 1.7.4 Improperly handled, installed or maintained; or
- 1.7.5 Altered or modified prior to or after installation; or
- 1.7.6 Damaged directly or indirectly by power surges, electrical storm damage or connection to incorrect power supply
- 1.7.7 Industrial and or Commercial usage is inclusive of staff areas in office/ shop environments, hotel motel or other similar accommodation or rental type properties including Bed and Breakfast establishments.

**The Australian Consumer Law requires the inclusion of the following statement with this warranty:**

*Our goods come with guaranteed that cannot be excluded under the Australian Consumer Law. You are entitled to a replacement or refund for a major failure and for compensation for any other reasonably foreseeable loss or damage. You are also entitled to have the goods repaired or replaced if the goods fail to be of acceptable quality and the failure.*

- 1.8 You must provide proof of your purchase of the Mistral product and the date of purchase in order to obtain the benefit of this warranty.
- 1.9 If you live outside the service area of the Company or one of its service agents, this warranty does not cover the cost of transport of the Mistral product for service nor the service agent's traveling costs to and from your home.
- 1.10 If you are required to transport the Mistral product to the Company or its service agent, you must ensure it is safely disconnected by a qualified tradesman and securely packed and insured. The Company does not accept any responsibility for loss or damage of the Mistral product prior to it being received by the Company or its service agent.
- 1.11 You will be responsible for all costs of returning a Mistral product to the Company and for redelivery of the Mistral product by the Company (whether it is the original or a repaired and/or a replacement Mistral product) and for any other expenses you incur in claiming under this warranty.
- 1.12 The Company or its service agent will examine any Mistral product and if the Company determines that it is defective through no fault of the Owner and is otherwise undamaged, the Company will repair or replace the Mistral product in accordance with this warranty.

**DO NOT SEND IN THIS WARRANTY**

Fill out the following details and file with your purchase invoice.

**RETAIN & FILE WITH YOUR RECEIPT**

Your purchase receipt/invoice is proof of date of purchase. If you are unable to establish the date of purchase, or if the fault is not covered by this warranty, or if the product is found to be in working order, you will be required to bear all service call charges.

GSM Retail Australia Pty Ltd reserves the right to discontinue items, modify designs and change specifications without incurring obligation.

Whilst every effort is made to ensure that descriptions, specifications and other information in this publication is correct, no warranty is given in respect thereof and the company shall not be liable for any errors there in. Purchased from:

**Co. Name:**

**Address:**

**Date of Purchase:**

**Serial number:**

**NOTE:** Consistent with our continuing product development policy, improvements may have been made which render the contents of this packaging slightly different to that

**FOR TECHNICAL ENQUIRIES CALL  
1300 373 199 (AUSTRALIA)  
0800 764 912 (NEW ZEALAND)  
TO CONNECT YOU TO THE NEAREST AUTHORISED SERVICE CENTRE**



Gerard Sourcing & Manufacturing

**GSM Retail Australia PTY LTD**

GSM Retail Group has a policy of continual improvement throughout the product range. As such the unit contained within may differ slightly from the unit illustrated on the pack.

MADE IN CHINA for GSM Retail Australia Pty Ltd. Group Companies



